



HANDBOOK

# SAFETY DEVICES FOR REFRIGERATING SYSTEMS

---



# INDEX

Safety valves 3030	07
Safety valves 3060	13
Ball shut-off valves for safety valves	16
Changeover devices for safety valves	18
Safety valves unions	20
Bursting disc safety devices 3070	21
Fusible plugs	25

---

## FROM QUALITY OUR NATURAL DEVELOPMENT

Achieved the goal of fifty years working in the industry of Refrigeration and Air Conditioning, Castel Quality Range of Products is well known and highly appreciated all over the world. Quality is the main issue of our Company and it has a special priority, in every step, all along the production cycle. UNI EN ISO 9001:2008, issued by ICIM, certifies the Quality System of the Factory. Moreover Castel Products count a number of certifications in conformity with EEC Directives and with European and American Quality Approval. We produce on high tech machinery and updated automatic production lines, operating in conformity with the safety and environment standards currently enforced. Castel offers to the Refrigeration and Air Conditioning Market and to the Manufacturers fully tested products suitable with HCFC and HFC Refrigerants currently used in the Refrigeration & Air Conditioning Industry.





## External leakage

All the products illustrated in this Handbook are submitted, one by one, to tightness tests besides to functional tests. Allowable external leakage, measurable during the test, agrees to the definition given in Par. 9.4 of EN 12284 : 2003 Standard:

*“During the test, no bubbles shall form over a period of at least one minute when the specimen is immersed in water with low surface tension, ...”*

## Pressure containment

All the products illustrated in this Handbook, if submitted to hydrostatic test, guarantee a pressure strength at least equal to 1,43 x PS in compliance with the Directive 97/23/EC.

All the products illustrated in this Handbook, if submitted to burst test, guarantee a pressure strength at least equal to 3 x PS according to EN 378-2 : 2008 Standard.

## Weights

The weights of the items listed in this Handbook include packaging.

## Guarantee

All Castel products are covered by a 12 – months warranty. This warranty covers all products or parts thereof that turn out to be defective within the warranty period. In this case, at his own expenses, the customer shall return the defective item with a detailed description of the claimed defects. The warranty doesn't apply if the defect of Castel products are due to mistakes either by customer or by third parties such wrong installations, use contrary to Castel indications, tampering. In case of defects of its own products, Castel will only replace the defective goods and will not refund damages of any kind.

The technical data shown on this catalogue are indicative. Castel reserves the right to modify the same at any time without any previous notice.

The products listed in this handbook are protected according to the law.





## GENERAL DESCRIPTION

Valves series 3030 are safety devices according to the definition given in Article 1, Point 2.1.3, 2nd dash of 97/23/EC Directive and are the subject of Article 3, Point 1.4 of aforesaid Directive.

The valves above mentioned are standard type, unbalanced, direct-loaded safety valves. Valve opening is produced by the thrust the fluid under pressure exerts on the disc, when said thrust exceeds, under setting conditions, the opposing force of the spring acting on the disc.

Valves are identified by means of:

- a model number formed of an alphanumerical coding that includes:
  - in the first part the family identification (e.g. 3030/44C)
  - in the second part the setting pressure, expressed in bars, multiplied by 10 (e.g. 140)
- an alphanumerical serial number.

## CONSTRUCTION

**Body:** squared, obtained through die forging and subsequent machining. It houses the following elements:

- the nozzle with flat sealing seat
- the disc guide
- the setting spring holder
- the threaded seat of the setting adjusting ring nut

In the body, above the disc guide, a small pressure relief hole is provided through which the spring holder is put into contact with the atmosphere. For this reason, during relief, a

gas leak occurs through this orifice.

Utilized material: EN 12420-CW617N brass.

**Disc:** obtained through bar machining and equipped with gasket, it ensures the required sealing degree on the valve seat. The gasket is made in P.T.F.E. (Polytetrafluorethylene), a material that, during valve estimated service life, maintains a good strength and does not cause the disc to stick on the seat. The disc is properly guided in the body and the guide action can never fail; there are no glands or retaining rings that hamper the movement thereof.

Utilized material: EN 12164-CW614N brass.

**Spring:** it opposes the pressure and the fluid dynamic actions and always ensures valve re-closing after pressure relief. The spring coils, when the disc has reached the lift corresponding to the state of relief at full flow rate, are spaced apart by at least half the wire diameter and, in any case, by not less than 2 mm. The disc is equipped with a mechanic lock and when it attains it, the spring set does not exceed 85% of the total set.

Utilized material: DIN 17223-1 steel for springs.

**Setting system:** hexagonal head, threaded ring nut to be screwed inside the body top by compressing the spring below. On setting completion, the position attained by the ring nut is maintained unchanged laying, in the threaded coupling, a bonding agent with high mechanic strength and low viscosity features to make penetration thereof easier. The setting system is protected against subsequent unauthorized interventions by means of a cap nut that is screwed outside the body and is sealed with lead to it.

## SCOPE

**Use:** protection against possible overpressures of the apparatuses listed below, with regard to the operating conditions for which they have been designed:

- Refrigerating system and heat pump components, for instance: condensers, liquid receivers, evaporators, liquid accumulators, positive displacement compressor discharge, heat exchangers, oil separators, piping. (reference: EN 378-2:2008 Standard)
- Simple pressure vessels (reference: 87/404/ EEC Directive)

**Fluids:** the valves can be used with:

- Refrigerant fluids, in the physical state of gas or vapour, belonging to Group 2 according to the definitions of 97/23/EC Directive, Article 9, Point 2.2 (with reference to 67/548/EEC Directive of June 27th, 1967).
- Air and nitrogen (reference: 87/404/EEC Directive)

## MARKING

In conformity with the provisions of Article 15 of 97/23/EC Directive, the EC marking and the identification number of

the notified body involved in the production control phase are reported on the valve body.

Still on the body, the following information is indicated:

- Manufacturer's mark, address and manufacture country
- Valve model
- Flow section
- Kd discharge coefficient
- Indication of flow direction
- Max allowable pressure
- Allowable temperature range
- Set pressure
- Production date
- Serial number

## VALVE SELECTION

97/23/EC Directive requires that pressure equipment, in which permissible limits are reasonably likely to be exceeded, shall be fitted with suitable protection devices, for instance safety devices such as safety valves. Such devices shall prevent pressure from permanently exceeding the max allowable pressure PS of the equipment they protect. In any case, a short pressure peak limited to 10% of admissible maximum pressure is permitted.

As to the selection and sizing of the suitable protection device, users shall refer to the specific product and sector standards.

EN ISO 4126-1: 2004 Standard: "Safety devices for protection against excessive pressure – Part 1: Safety valves", harmonized with 97/23/EC Directive, specifies general requirements for safety valves irrespective of the fluid for which they are designed.

EN 378-2 : 2008 Standard "Refrigerating systems and heat pumps – safety and environmental requirements – Part 2: Design, construction, testing, marking and documentation", harmonized with 97/23/EC Directive,

provides a general outline of the protection devices to be adopted in refrigerating systems and their features (par. 6.2.5). It also indicates the criteria for the selection of the device suitable to the type and sizes of the system component to be protected (par. 6.2.6).

EN 13136:2001/A1:2005 Standard "Refrigerating systems and heat pumps – Pressure relief devices and their associated piping – Methods for calculation", harmonized with 97/23/EC Directive, highlights the possible causes of overpressure in a system and makes available to users the instruments for pressure relief device sizing, among which the safety valves.

## SIZING OF SAFETY VALVES DESIGNED TO DISCHARGE GAS OR VAPOUR AT CRITICAL FLOW (Ref. . EN ISO 4126-1: 2004 and EN 13136 : 2001/A1:2005)

Critical flow occurs when the backpressure pb (the pressure existing immediately at the outlet of a safety valve) is below or equal to the critical pressure:

$$P_b \leq P_o \left| \frac{2}{k+1} \right|^{\left( \frac{k}{k-1} \right)} \quad [\text{bar abs}]$$

with:

- $p_o$  = actual relieving pressure, upstream the safety valve; it's equal to the set pressure plus overpressure. That is a pressure increase over set pressure at which the disc has its total lift. [bar abs]
- $k$  = isentropic exponent of gas or vapour, based on the actual flowing conditions at the safety valve inlet

If  $k$  is unknown or anyway difficult to establish it's possible to suppose:

$$P_{\text{critical}} = 0,5 \times P_o \quad [\text{bar abs}]$$

TABLE 1: General Characteristics of valves 3030

Catalogue Number		3030/44C	3030/66C	3030/88C
Connections	Inlet male	1/2" NPT	3/4" NPT	1" NPT
	Outlet male	3/4" G	3/4" G	1.1/4" G
Inlet connection wrench torque (min/max) [Nm]		21/30	32/45	50/65
Flow Diameter [mm]		12	12	19,5
Flow Section [mm <sup>2</sup> ]		113	113	298
Lift [mm]		4,1	4,1	6,8
Discharge Coefficient "Kd"		0,90	0,90	0,83
PS [bar]		55		
TS [°C]		- 50 / + 150		
Set Pressure Range [bar]		8 / 50		
Overpressure		5 % of set pressure		
Blowdown		15 % of set pressure		
Risk Category according to PED		IV		



A safety valve, which discharges to atmosphere, works in critical flow.

The safety valves designed to discharge gas or vapour at critical flow must be sized as follow:

$$A_c = 3,469 \times \frac{Q_{md}}{C \times 0,9 \times K_d} \times \sqrt{\frac{v_o}{p_o}} \quad [\text{mm}^2]$$

with:

- $A_c$  = minimum flow area of safety valve [mm<sup>2</sup>]
- $Q_{md}$  = minimum required discharge capacity, of refrigerant, of safety valve [kg/h]
- $K_d$  = certified coefficient of discharge
- $p_o$  = actual relieving pressure, upstream the safety valve, see definition above. [bar abs]
- $v_o$  = specific volume of gas or vapour at relieving conditions  $p_o$  e  $T_o$ , meaning with  $T_o$  fluid temperature at valve inlet, settled by the user or by the designer. [m<sup>3</sup>/kg]
- $C$  = function of isentropic coefficient  $k$  calculated from:

$$C = 3,948 \times \sqrt{k \times \frac{2}{k+1} \left| \frac{k+1}{k-1} \right|}$$

for this calculation the value of  $k$  shall be as measured at 25 °C. (Section 7.2.3, EN 13136:2001/A1:2005 Standard). Values of  $k$  and calculated values of  $C$  for all the refrigerants are given in table A.1 of the aforesaid Standard. Following we show the values of  $k$  and  $C$  for the more useful refrigerants.

Refrigerant	Isentropic Coefficient $k$	Function of Isentropic Coefficient $C$
R22	1,17	2,54
R134a	1,12	2,50
R404A	1,12	2,50
R407C	1,14	2,51
R410A	1,17	2,54
R507	1,10	2,48

Calculation of minimum required discharge capacity of safety valve is closely linked to the type of system where the valve is installed, with the causes that may arouse the opening of safety valve, i.e.:

- External heat sources. The minimum required discharge capacity shall be determined by the following:

$$Q_{md} = \frac{3600 \times \varphi \times A_{surf}}{h_{vap}} \quad [\text{Kg/h}]$$

with:

- $\varphi$  = density of heat flow rate, it's assumed to be 10 [kW/m<sup>2</sup>]
- $A_{surf}$  = external surface area of the vessel [m<sup>2</sup>]
- $h_{vap}$  = heat of vaporization of liquid at  $p_o$  [kJ/kg]
- Internal heat sources. The minimum required discharge capacity shall be determined by the following:

$$Q_{md} = \frac{3600 \times Q_h}{h_{vap}} \quad [\text{Kg/h}]$$

with  $Q_h$  = rate of heat production [KW]

- Excessive pressure caused by compressors. The minimum required discharge capacity shall be determined by the following:

$$Q_{md} = 60 \times V \times n \times \rho_{10} \times \eta_v \quad [\text{Kg/h}]$$

with:

- $V$  = theoretical displacement of compressor [m<sup>3</sup>]
- $n$  = rotational frequency of compressor [min<sup>-1</sup>]
- $\rho_{10}$  = vapour density at refrigerant saturation pressure/ dew point at 10 °C [kg/m<sup>3</sup>]
- $\eta_v$  = volumetric efficiency estimated at suction pressure and discharge pressure equivalent to the safety valve setting

### EXAMPLE OF CALCULATION OF MINIMUM REQUIRED DISCHARGE CAPACITY $Q_{md}$ AND SIZING OF THE SAFETY VALVE FOR THE HIGH PRESSURE SIDE OF A REFRIGERATING SYSTEM

#### System description

Compact refrigerating system designed to make refrigerated water and consisting of:

- open type reciprocating compressor.
- Water-cooled, shell-and-tube horizontally condenser with lower section of shell used as receiver.
- Shell-and-tube horizontally liquid cooler fed with a thermostatic valve.
- Refrigerant fluid R407C

#### Compressor data

- Bore 82,5 mm
- Stroke 69,8 mm
- Cylinder number 6
- Rotational frequency 1450 rpm
- Clearance 4%

The theoretical displacement of compressor is:

$$V = \frac{\pi}{4} \times 0,0825^2 \times 0,0698 \times 6 = 0,00224 \quad [\text{m}^3]$$

Maximum allowable pressure of the condenser, refrigerant side : PS = 25 bar

Set pressure of the safety valve installed on the upper shell section of condenser:

$$p_{set} = 25 \text{ bar}$$

Actual relieving pressure of safety valve, choosing one valve type 3030 with an overpressure of 5%:

$$p_o = p_{set} \times \left( 1 + \frac{5}{100} \right) + 1 = 27,25 \quad [\text{bar abs}]$$

Working conditions of compressor corresponding to the relieving of safety valve:

- Condensing temperature: + 64 °C (27,25 bar abs)
- Evaporating temperature: + 10 °C (6,33 bar abs)

These conditions, settled in any case by the designer, are considered the most unfavorable for the safety valve in

consequence of functional defects as:

- Move mistake
- Non-working of automatic safety devices, set to operate before safety valve.

It shall be excluded

- Closeness the refrigerating system, the presence of flammable substances in so large quantities to be able to feed a fire.
- Inside the vessel, the presence of a heat source.

### Calculation of minimum discharge capacity

Prudentially leaving the vapour overheating at the outlet of the liquid cooler out of account, the volumetric efficiency of compressor is:

$$\eta_v = 1 - 0,04 \frac{P_{\text{discharge}}}{P_{\text{suction}}} = 1 - 0,04 \frac{27,25}{6,33} = 0,83$$

and so the minimum required discharge capacity:

$$Q_{\text{md}} = 60 \times V \times n \times \rho_{10} \times \eta_v = 60 \times 0,00224 \times 1450 \times 26,34 \times 0,83 = 4260 \text{ [Kg/h]}$$

with  $\rho_{10} = 26,34 \text{ [kg/m}^3\text{]}$ , vapour density of R407C at saturation pressure / dew point at 10 °C

### Sizing of minimum flow area of the safety valve

$$A_c = 3,469 \times \frac{Q_{\text{md}}}{C \times 0,9 \times K_d} \times \sqrt{\frac{v_o}{p_o}} = 3,469 \times \frac{4260}{2,51 \times 0,9 \times 0,83} \times \sqrt{\frac{0,0104}{27,25}} = 154 \text{ [mm}^2\text{]}$$

with:

- $C = 2,51$ , corresponding to isentropic exponent  $k$  for R407C equal to 1,14, according to table A1 of EN 13136:2001/A1:2005 Standard
- $K_d = 0,83$ , certified coefficient of discharge for safety valve 3030/88
- $v_o = 0,0104 \text{ [m}^3\text{/kg]}$ , specific volume of overheating vapour upstream the safety valve during relieving. This value is referred to the following operating conditions, upstream the safety valve:
  - pressure  $p_o = 27,25 \text{ [bar abs]}$
  - temperature  $T_o = 100 \text{ [}^\circ\text{C]}$  (precautionary temperature, settled in any case by the designer)

**Conclusion:** the selected safety valve is the model 3030/88 with the following characteristics:

- certified coefficient of discharge,  $K_d = 0,83$
- flow section,  $A_c = 298 \text{ [mm}^2\text{]}$
- set pressure,  $p_{\text{set}} = 25 \text{ bar}$

In case of single-screw compressor with injection of pressurized oil, the theoretical displacement is:

$$V_c = \frac{\pi \times D^2}{4} \times L \text{ [m}^3\text{]}$$

with:

- $D = \text{rotor diameter [m]}$
- $L = \text{rotor length [m]}$

## VALVE INSTALLATION

**Safety valves type 3030 are guaranteed for reproducibility of performance, this means that after the valves have operated, open/close, the initial setting conditions are maintained.** Nevertheless it is advisable to replace valve 3030 once it has discharged because during release, piping debris, as metal shavings or solder impurities, can place on the valve gasket and then, inhibits the safety valve from reseating at its originally conditions. As far as the installation of safety relief valves is concerned, the fundamental points listed below shall be taken into account:

- Safety valves shall be installed near an area of the system where vapours or gases are present and there is no fluid turbulence; the position shall be as upright as possible, with the inlet connector turned downwards.
- Vessels, joined together with piping rightly selected by the manufacturer and without any stop valve between them, may be considered as only one vessel for the installation of a safety valve.
- The union between the valve and the equipment to be protected shall be as short as possible. Furthermore, its passage section shall not be narrower than the valve inlet section. In any case, EN 13136:2001/A1:2005 Standard states that the pressure loss between protected vessel and safety valve, at discharge capacity, shall not exceed 3% of the setting value, including any accessory mounted on the upstream line.
- In selecting the safety valve location, it shall be taken into account that valve operation involves the discharge of the refrigerant fluid under pressure, sometimes even at high temperature. Where the risk exists to cause direct injuries to the persons nearby, an exhaust conveying piping shall be provided, which shall be sized in such a way as not to compromise valve operation. EN 13136:2001/A1:2005 Standard states that this piping shall not generate, at discharge capacity, a back pressure exceeding 10% of pressure  $p_o$ , for standard type valves, unbalanced.

To calculate the pressure loss either in the upstream line (between vessel and safety valve) or in the downstream line (between safety valve and atmosphere) refer to EN 13136:2001/A1:2005 Standard, Chapter 7.4.

### Pressure loss in the upstream line

Calculation of pressure loss is given by:

$$\frac{\Delta p_{\text{in}}}{p_o} = 0,032 \times \left[ \frac{A_c}{A_{\text{in}}} \times C \times K_{\text{dr}} \right]^2 \times \xi$$

with:

- $A_c = \text{minimum calculated flow area [mm}^2\text{]}$
- $A_{\text{in}} = \text{inside area of inlet tube to valve [mm}^2\text{]}$
- $K_{\text{dr}} = K_d \times 0,9$ , derated coefficient of discharge
- $C = \text{function of isentropic coefficient } k$
- $\xi = \text{addition of pressure loss coefficients } \xi_n \text{ of any component and piping}$

The coefficients  $\xi_n$  are relevant to:

- pipe elements loss, as connections and bends
- valves loss
- loss along the pipe

and are listed in EN 13136:2001/A1:2005 Standard, Table A.4.

**Example:** assume to install, on the condenser of the previous example, a safety valve type 3030/88, set to 25 bar, using a steel union with the following characteristics:

- $d_{in} = 28$  [mm], inside diameter
- $A_{in} = 616$  [mm<sup>2</sup>] inside area
- $L = 60$  [mm], length
- Flush connection to the shell of condenser, with a broken edge

From table A.4 it's possible to have these data:

- $\xi_{1(\text{inlet})} = 0,25$
- $\xi_{2(\text{length})} = \lambda \times L / d_{in} = 0,02 \times 60 / 28 = 0,043$   
with  $\lambda = 0,02$  for steel tube
- $\xi_T = \xi_1 + \xi_2 = 0,25 + 0,04 = 0,293$

Between safety valve and union it's installed a shut-off valve type 3033/88.

The main characteristics of this valve are:

- $d_R = 20$  [mm], inside diameter
- $A_R = 314$  [mm<sup>2</sup>], inside area
- $kv = 20$  [m<sup>3</sup>/h], kv factor

Pressure loss coefficient  $\xi_R$  of shut-off valve is given by:

$$\xi_R = 2,592 \times \left[ \frac{314}{20} \right]^2 \times 10^{-3} = 0,64$$

The total pressure loss coefficient is:  $\xi_T + \xi_R = 0,933$

We remember the previous calculated flow area, the characteristics of safety valve 3030/88 and refrigerant fluid R407C:

- $A_c = 154$  [mm<sup>2</sup>]
- $K_{dr} = 0,83 \times 0,9 = 0,747$
- $C = 2,51$

Pressure loss in the upstream line is:

$$\frac{\Delta p_{in}}{p_o} = 0,032 \times \left[ \frac{154}{616} \times 2,51 \times 0,747 \right]^2 \times 0,933 = 0,00656$$

The obtained value is admissible because lower than the value of 0,03 forecast in EN 13136:2001/A1:2005 Standard.

#### Pressure loss in the downstream line

Calculation of pressure loss is given by:

$$p_1 = \sqrt{0,064 \times \xi \times \left( \frac{A_c}{A_{out}} \times C \times K_{dr} \times p_o \right)^2} + p_2^2$$

with:

- $P_1$  = inlet pressure to downstream line [bar abs]
  - $P_2$  = outlet pressure to downstream line, equal to atmospheric pressure [bar abs]
  - $A_c$  = minimum calculated flow area [mm<sup>2</sup>]
  - $A_{out}$  = inside area of outlet tube to valve [mm<sup>2</sup>]
  - $K_{dr} = K_d \times 0,9$ , derated coefficient of discharge
  - $p_o$  = actual relieving pressure, upstream the safety valve [bar abs]
  - $C$  = function of isentropic coefficient  $k$
  - $\xi$  = addition of pressure loss coefficients  $\xi_n$  of piping  
The coefficients  $\xi_n$  are relevant to:
    - pipe elements loss, bends
    - loss along the pipe
- and are listed in EN 13136:2001/A1:2005 Standard, Table A.4

**Example:** assume to install a discharge pipe on safety valve type 3030/88 of the previous example, using a steel tube nominal size 1.1/2" GAS with the following characteristics:

- $d_{out} = 42,5$  [mm], inside diameter
- $A_{out} = 1418$  [mm<sup>2</sup>], inside area
- $L = 3000$  [mm], length
- pipe bend 90° with bending radius  $R$  equal to three times external diameter of tube

From table A.4 it's possible to have these data:

- $\xi_{1(\text{bend})} = 0,25$
- $\xi_{2(\text{length})} = \lambda \times L / d_{in} = 0,02 \times 3000 / 42,5 = 1,41$  with  $\lambda = 0,02$  for steel tube
- $\xi_T = \xi_1 + \xi_2 = 0,25 + 1,41 = 1,66$

Pressure loss in the downstream line is:

$$p_1 = \sqrt{0,064 \times 1,66 \times \left( \frac{154}{1418} \times 2,51 \times 0,747 \times 27,25 \right)^2} + 1^2 = 2,125 \text{ [bar]}$$

$$\frac{\Delta p_{out}}{p_o} = \frac{2,125 - 1}{27,25} = 0,041$$

The obtained value is admissible because lower than the value of 0,10 forecast in EN 13136:2001/A1:2005 Standard.

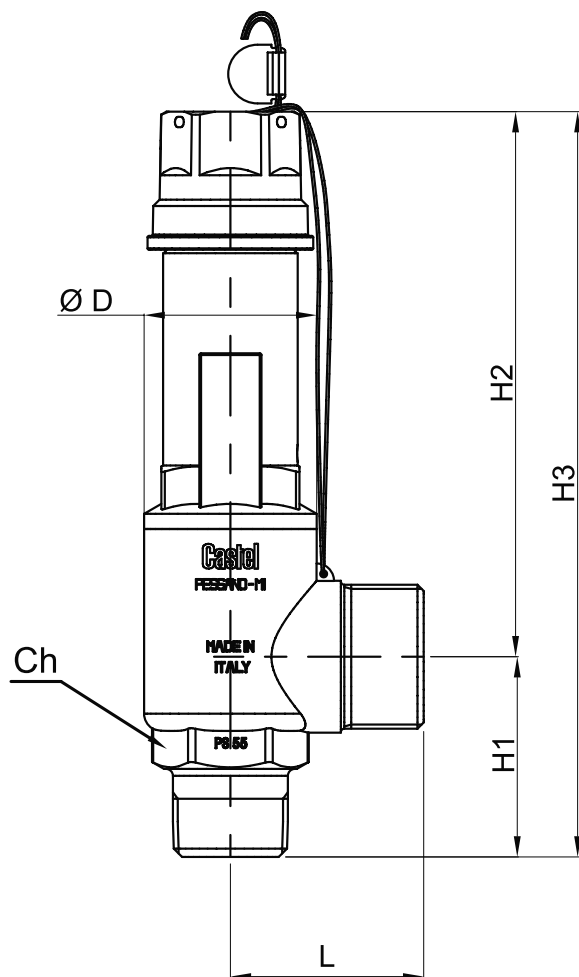

TABLE 2: Dimensions and Weights of valves 3030

Catalogue Number	Dimensions [mm]						Weight [g]
	$\varnothing D$	L	Ch	$H_1$	$H_2$	$H_3$	
3030/44C	38	38	28	44	115	159	780
3030/66C	38	38	28	44	115	159	780
3030/88C	50	56	40	58	158	216	1960



## GENERAL DESCRIPTION

Valves series 3060 are safety devices according to the definition given in Article 1, Point 2.1.3, 2nd dash of 97/23/EC Directive and are the subject of Article 3, Point 1.4 of aforesaid Directive.

The valves above mentioned are standard type, unbalanced, direct-loaded safety valves. Valve opening is produced by the thrust the fluid under pressure exerts on the disc, when said thrust exceeds, under setting conditions, the opposing force of the spring acting on the disc.

Valves are identified by means of:

- a model number formed of an alphanumeric coding that includes:
  - in the first part the family identification (e.g. 3060/45C)
  - in the second part the setting pressure, expressed in bars, multiplied by 10 (e.g. 140)
- an alphanumeric serial number.

## CONSTRUCTION

**Body:** squared, obtained through die forging and subsequent machining. It houses the following elements:

- the nozzle with flat sealing seat
- the disc guide
- the setting spring holder
- the threaded seat of the setting adjusting ring nut

In the body, above the disc guide, a small pressure relief duct is provided through which the spring holder is put into contact with the output connection.

Utilized material: EN 12420-CW617N brass.

**Disc:** obtained through bar machining and equipped with gasket, it ensures the required sealing degree on the valve seat. The gasket is made in P.T.F.E. (Polytetrafluorethylene), a material that, during valve estimated service life, maintains a good strength and does not cause the disc to stick on the seat. The disc is properly guided in the body and the guide action can never fail; there are no glands or retaining rings that hamper the movement thereof.

Utilized material: EN 12164-CW614N brass

**Spring:** it opposes the pressure and the fluid dynamic actions and always ensures valve re-closing after pressure relief.

Utilized material: DIN 17223-1 steel for springs.

**Setting system:** hexagonal head, threaded ring nut to be screwed inside the body top by compressing the spring below. On setting completion, the position attained by the ring nut is maintained unchanged laying, in the threaded coupling, a bonding agent with high mechanic strength and low viscosity features to make penetration thereof easier. The setting system is protected against subsequent unauthorized interventions by means of a cap nut that is housed into the brass body and is fixed in this seat with an edge calking operation.

## SCOPE

**Use:** protection against possible overpressures of the apparatuses listed below, with regard to the operating conditions for which they have been designed:

- Refrigerating system and heat pump components, for instance: condensers, liquid receivers, evaporators, liquid accumulators, positive displacement compressor discharge, heat exchangers, oil separators, piping. (reference: EN 378-2:2008 Standard)
- Simple pressure vessels (reference: 87/404/ EEC Directive)

**Fluids:** the valves can be used with:

- Refrigerant fluids, in the physical state of gas or vapour, belonging to Group 2 according to the definitions of 97/23/EC Directive, Article 9, Point 2.2 (with reference to 67/548/EEC Directive of June 27<sup>th</sup>, 1967).
- Air and nitrogen (reference: 87/404/EEC Directive)

## MARKING

In conformity with the provisions of Article 15 of 97/23/EC Directive the following information are reported on the valve body.

- Manufacturer's mark, address and manufacture country
- Indication of flow direction
- Max allowable pressure
- Set pressure
- Allowable temperature range
- Production date

- Serial number

The following data are stamped on the cap:

- EC marking and the identification number of the notified body involved in the production control phase
- Valve model
- Flow section
- Kd discharge coefficient

## VALVE SELECTION

97/23/EC Directive requires that pressure equipment, in which permissible limits are reasonably likely to be exceeded, shall be fitted with suitable protection devices, for instance safety devices such as safety valves. Such devices shall prevent pressure from permanently exceeding the max allowable pressure PS of the equipment they protect. In any case, a short pressure peak limited to 10% of admissible maximum pressure is permitted.

As to the selection and sizing of the suitable protection device, users shall refer to the specific product and sector standards.

EN ISO 4126-1: 2004 Standard: "Safety devices for protection against excessive pressure – Part 1: Safety valves", harmonized with 97/23/EC Directive, specifies general requirements for safety valves irrespective of the fluid for which they are designed.

EN 378-2 : 2008 Standard "Refrigerating systems and heat pumps – safety and environmental requirements – Part 2: Design, construction, testing, marking and documentation", harmonized with 97/23/EC Directive, provides a general outline of the protection devices to be adopted in refrigerating systems and their features (par. 6.2.5). It also indicates the criteria for the selection of the device suitable to the type and sizes of the system component to be protected (par. 6.2.6).

EN 13136:2001/A1:2005 Standard "Refrigerating systems and heat pumps – Pressure relief devices and their associated piping – Methods for calculation", harmonized with 97/23/EC Directive, highlights the possible causes of overpressure in a system and makes available to users the instruments for pressure relief device sizing, among which the safety valves.

For sizing of safety valves series 3060 see the previous chapter of safety valves series 3030.

## VALVE INSTALLATION

Safety valves type 3060 are **NOT** guaranteed for reproducibility of performance, this means that after the valves have operated, open/close, the initial setting conditions are **NOT** maintained. Then it is necessary to replace valve 3060 once it has discharged.

For installation of safety valves series 3060 see the previous chapter of safety valves series 3030.

Utilized material: EN 12164-CW614N brass.

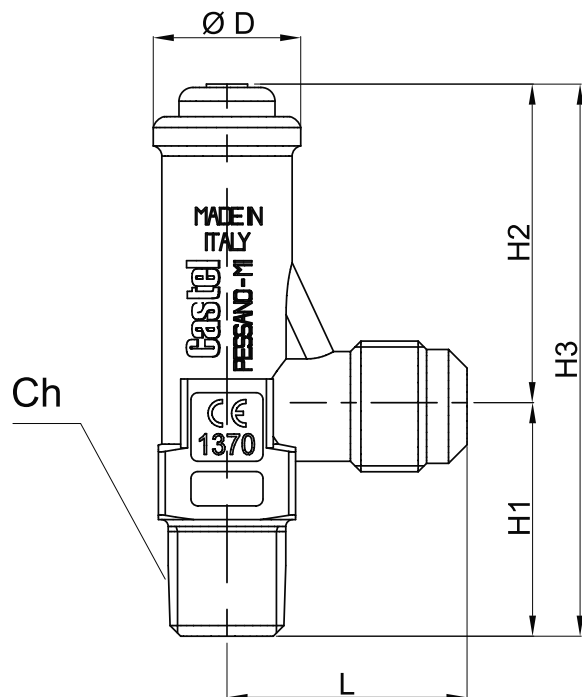

**TABLE 3: General Characteristics of valves 3060**

Catalogue Number		3060/23C	3060/24C	3060/33C	3060/34C	3060/45C	3060/36C	3060/46C
Connections	Inlet male	1/4" NPT	1/4" NPT	3/8" NPT	3/8" NPT	1/2" NPT	3/8" NPT	1/2" NPT
	Outlet male	3/8" SAE	1/2" SAE	3/8" SAE	1/2" SAE	5/8" SAE	3/4" G	3/4" G
Inlet connection wrench torque (min/max) [Nm]		10/15	10/15	14/20	14/20	21/30	14/20	21/30
Flow Diameter [mm]		7,0				9,5	10,0	
Flow Section [mm <sup>2</sup> ]		38,5				70,9	78,5	
Discharge Coefficient "Kd"		0,63	0,69	0,63	0,69	0,45	0,92	0,93
PS [bar]		55						
TS [°C]		- 50 / + 150						
Set Pressure Range [bar]		9 / 50						
Overpressure		10 % of set pressure						
Risk Category according to PED		IV						

**TABLE 4: Dimensions and Weights of valves 3060**

Catalogue Number	Dimensions [mm]						Weight [g]
	Ø D	L	Ch	H <sub>1</sub>	H <sub>2</sub>	H <sub>3</sub>	
3060/23C	21,5	35	20	33,5	46,5	80	180
3060/24C	21,5	35	20	33,5	46,5	80	195
3060/33C	21,5	35	20	33,5	46,5	80	195
3060/34C	21,5	35	20	33,5	46,5	80	195
3060/45C	24,5	39,0	23	37	52,5	89	240
3060/36C	30	40	27	37	59,5	96,5	360
3060/46C	30	40	27	40	59,5	99,5	380

# BALL SHUT-OFF VALVES FOR SAFETY VALVES



## APPLICATIONS

We would like to remember to our customer that the running of pressure equipments and pressure assemblies is excluded by the scope of Directive 97/23/EC but it's regulated in compliance with national regulations of Member States of European Communities.

We think that these regulations, actually on updating with the Competent Bodies of all the states to avoid conflicts with the ESR of PED, could provide for periodical checks on the pressure equipments and assemblies.

Any intervention for periodic checking or replacement of an installed safety valve becomes very difficult if the protected vessel is not equipped with a shut-off valve.

The shut-off valves series 3033 and 3063, installed between vessel and safety valve, allow removing the valve for periodic checking or replacement without blowing off all the refrigerant from a section of the system. These valves can be used with the same fluids foreseen for safety valves series 3030 and 3060, in particularly:

- Refrigerant fluids, in the physical state of gas or vapour, belonging to Group 2 according to the definitions of 97/23/EC Directive, Article 9, Point 2.2 (with reference to 67/548/EEC Directive of June 27<sup>th</sup>, 1967).
- Air and nitrogen (reference: 87/404/EEC Directive)

## CONSTRUCTION

Castel supplies to its customers the valves series 3033 and 3063 in open position and the ball spindle is protected by means of a cap screwed to the body and sealed with lead to it. Any closing intervention on the valve forcedly causes the tampering of the seal and then these interventions shall be performed exclusively by:

- staff authorized to work on the system
- public servant of a Competent Body

These persons will be responsible for the next valve reopening and the new cap sealing with their own lead.

The main parts of these valves are made with the following materials:

- Hot forged brass EN 12420 – CW 617N for body
- Hot forged brass EN 12420 – CW 617N, chromium plated, for ball
- Steel, with proper surface protection, for the spindle.
- P.T.F.E. for seat ball gaskets
- Chloroprene rubber (CR) for outlet seal gaskets
- Glass reinforced PBT for cap that covers the spindle



3033/44  
3033/88

3063/22  
3063/33  
3063/44

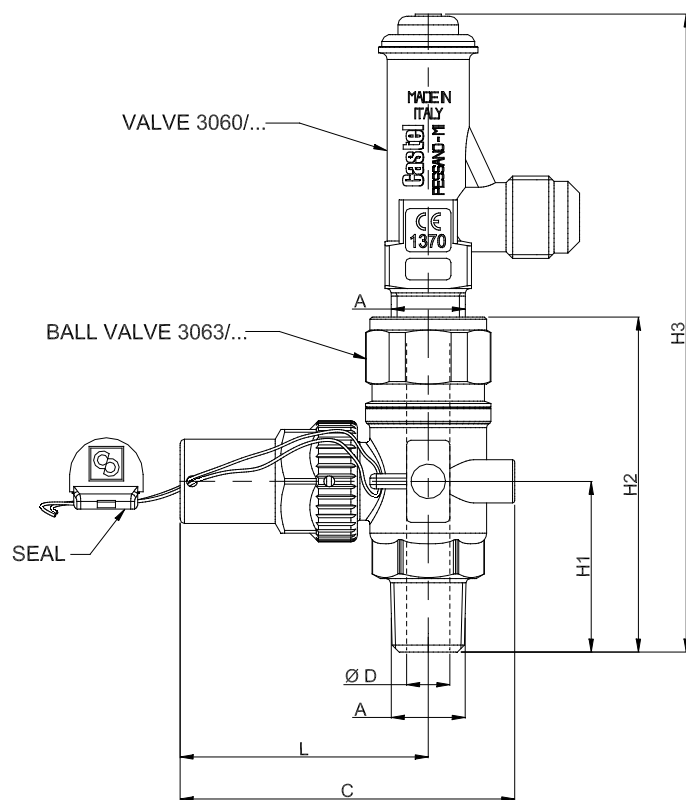
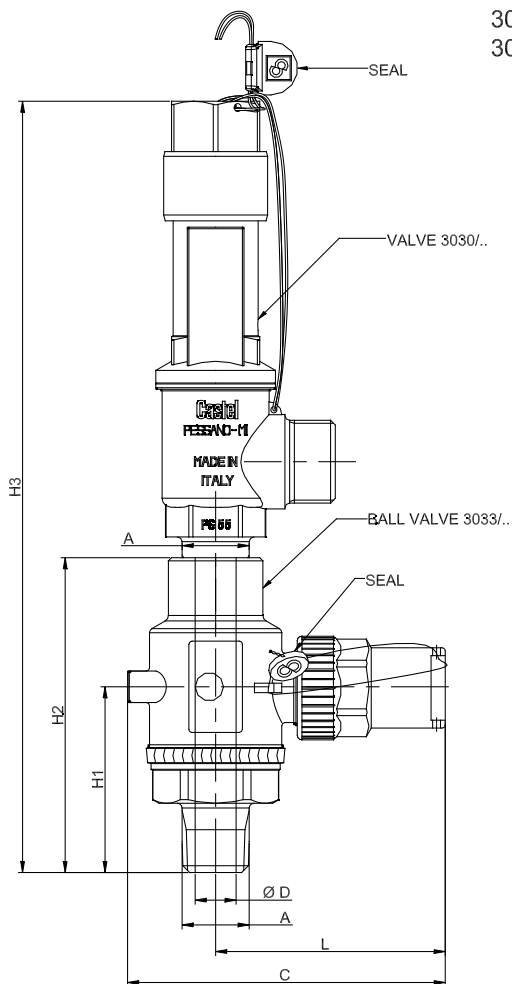

TABLE 5: General Characteristics, Dimensions and Weights of valves 3033, 3063

Catalogue Number	Designed for valve	Kv Factor [m³/h]	TS [°C]		PS [bar]	Dimensions [mm]							Inlet connection wrench torque (min/max) [Nm]	Weight [g]	Risk Category according to PED
			min	max		Ø D	A	C	L	H <sub>1</sub>	H <sub>2</sub>	H <sub>3</sub>			
3063/22	3060/23C 3060/24C	2,5	-50	+150	55	7	1/4" NPT	78	58	39,5	77,5	155	10/15	500	Art. 3.3
3063/33	3060/33C 3060/34C	5				10	3/8" NPT	78	58	39,5	77,5	155	14/20	530	
3063/44	3060/45C 3060/46C	5				10	1/2" NPT	78	58	44,5	84,5	162	21/30	560	
3033/44	3030/44C	10				13		101	73	59	100	245	21/30	710	
3033/88	3030/88C	20				20	1" NPT	107	77	72	123	323	50/65	1070	

# CHANGEOVER DEVICES FOR SAFETY VALVES



## APPLICATIONS

The changeover device type 3032 is a service valve for dual pressure relief valves that allows using one valve while isolating the other from the system. This device allows the user to work on the isolated valve, for periodic checking or replacement, while the system is completely operative and the other valve is in service.

N.B. : each safety valve placed on a changeover device must have sufficient capacity to protect the vessel alone.

Valve type 3032/33 is supplied with:

- Two female threaded connections 3/8" NPT with swivel nut, code Castel 3039/3
- two O-Ring

These components ensure the perfect alignment of two safety valves 3060/33 or 3060/34 or 3060/36.

Valve type 3032/44 is supplied with:

- Two female threaded connections 1/2" NPT with swivel nut, code Castel 3039/4
- two O-Ring

These components ensure the perfect alignment of two safety valves 3060/45 or 3060/46.

The valves series 3032 can be used with the same fluids foreseen for safety valves series 3030 and 3060, in particularly:

- Refrigerant fluids, in the physical state of gas or vapour, belonging to Group 2 according to the definitions of 97/23/EC Directive, Article 9, Point 2.2 (with reference to 67/548/EEC Directive of June 27th, 1967).
- Air and nitrogen (reference: 87/404/EEC Directive)

## CONSTRUCTION

The valve 3032 is designed so that it is never possible to close off both ports at the same time, excluding all the two safety valves. Under working conditions, the shutter must be clamped against one of the two seats of the valve, front port or back port, in order to ensure always full discharge to the corresponding safety valve. Intermediate positions of the shutter are not acceptable in order not to affect the operation of both safety valves. The valve ensures a pressure drop perfectly compatible with the safety valve operation under conditions of discharge of saturated vapour as well as overheated vapour.

The main parts of these valves are made with the following materials:

- Hot forged brass EN 12420 – CW 617N for body
- Steel, with proper surface protection, for the spindle
- Chloroprene rubber (CR) and aramidic fibers for gland seal
- Chloroprene rubber (CR) for outlet seal gaskets
- Glass reinforced PBT for cap that covers the spindle

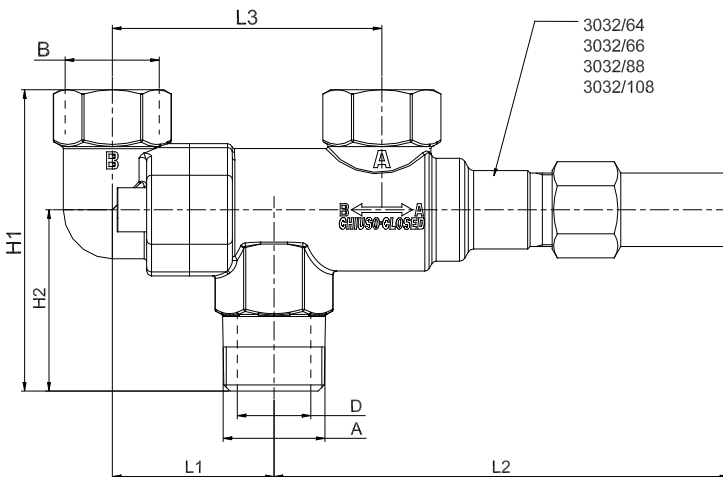
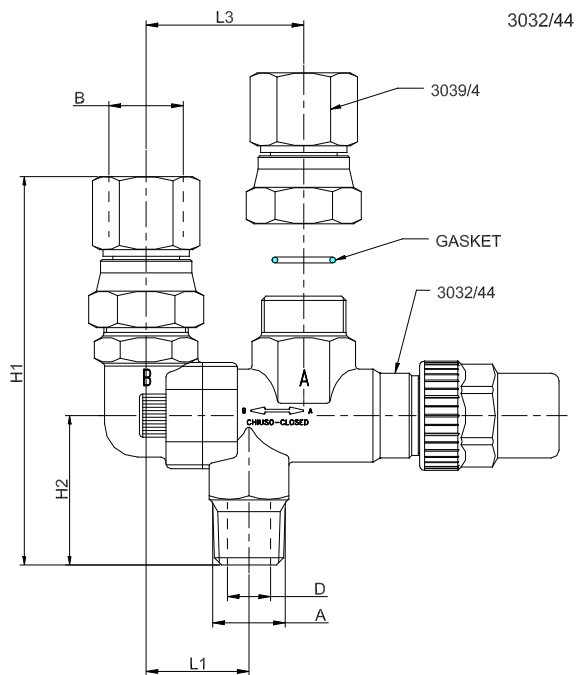
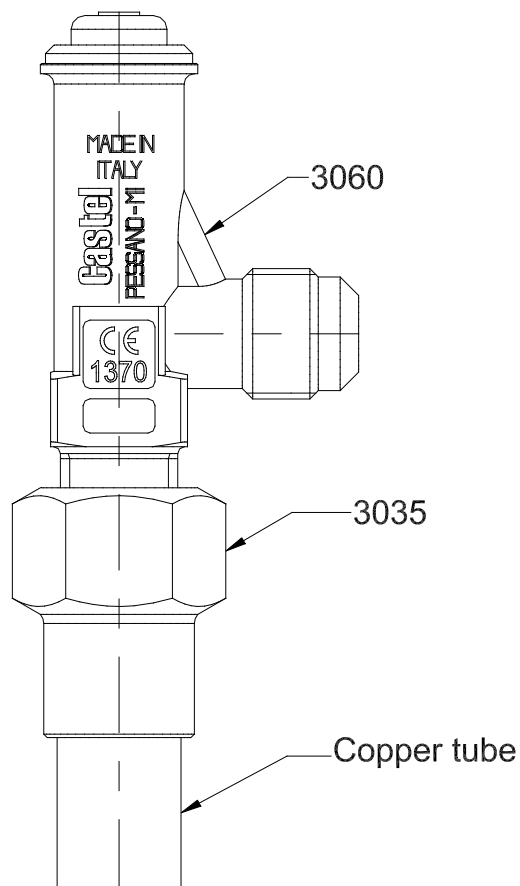

TABLE 6: General Characteristics, Dimensions and Weights of valves 3032

Catalogue Number	Designed for valve	Kv Factor [m <sup>3</sup> /h]	TS [°C]		PS [bar]	Dimensions [mm]							Inlet connection wrench torque (min/max) [Nm]	Weight [g]	Risk Category according to PED	
			min	max		D	A	B	H <sub>1</sub>	H <sub>2</sub>	L <sub>1</sub>	L <sub>2</sub>				L <sub>3</sub>
3032/33	3060/33C 3060/34C 3060/36C	2,5	-50	+150	55	13	3/8" NPT	3/8" NPT	117	45	33	91	50	14/20	775	Art. 3.3
3032/44	3060/45C 3060/46C	3,3				13	1/2" NPT	1/2" NPT	117	45	33	91	50	21/30	775	
3032/64	3030/44C	9,0				17,5	3/4" NPT	1/2" NPT	95	52	48	133	80	32/45	1750	
3032/66	3030/66C	9,0				17,5	3/4" NPT	3/4" NPT	95	52	48	133	80	32/45	1750	
3032/88	3030/88C	14,5				22,0	1" NPT	1" NPT	120	71	66	185	110	50/65	3200	
3032/108		20,0				31,0	1. 1/4" NPT	1" NPT	123	74	66	185	110	60/80	3200	

# SAFETY VALVES UNIONS



Unions series 3035 allow assembling safety valves series 3030 and 3060 or shut-off valves series 3032, 3033 and 3063 close to the pressure equipments to protect, set up in a refrigerating system.

These unions are designed for installations according to the following two ways:

- Make a copper tube joining the pressure equipment to the union, fit the end of this tube into the solder connection of the union and then make a capillary brazing.
- Drill the inner/outer pipe close to the pressure equipment (if possible make a collar on the pipe), put the end of the union into this drill and then make a braze welding.

The unions series 3035 are machined by brass bar EN 12164-CW614N

TABLE 7: General Characteristics, Dimensions and Weights of unions 3035

	Catalogue Number	Connections		PS [bar]	Dimensions [mm]			Weight [g]
		NPT	ODS Ø [mm]		D	L	Ch	
	3035/2	1/4"	12	55	18	33	21	58
	3035/3	3/8"	18		22	36,5	26	90,5
	3035/4	1/2"	22		28	44	32	165
	3035/6	3/4"	28		35	51	40	255
	3035/8	1"	35		42	72	45	364
	3035/10	1.1/4"	42		54	67	55	613

# BURSTING DISC SAFETY DEVICES 3070



## GENERAL DESCRIPTION

Bursting disc safety devices 3070 are safety devices according to the definition given in Article 1, Point 2.1.3, 2<sup>nd</sup> dash of 97/23/EC Directive and are the subject of Article 3, Point 1.4 of aforesaid Directive.

Safety device 3070 is a non-reclosing pressure relief device where the bursting disc is sensitive to a positive differential pressure between upstream and downstream and it is designed to burst at a specified pressure.

Safety devices 3070 are identified by means of:

- a model number formed of an alphanumerical coding that includes:
  - in the first part the family identification (e.g. 3070/44C)
  - in the second part the setting pressure, expressed in bars, multiplied by 10 (e.g. 140)
- a serial number for lot production

## CONSTRUCTION

**Bursting disc holder:** it is the body of the device, manufactured in two half parts screwed together, that holds the bursting disc in the proper position. The two half bodies are obtained through bar machining; the lower body houses the inlet connection, while the upper body houses the outlet connection and two service pressure 1/8"NPT.

**Bursting disc:** The discs are designed and tested, according to the requirements of EN ISO 4126-2:2003

Standard, to burst at an established pressure. This pressure is called specified burst pressure, quoted with a coincident temperature and with a performance tolerance. The disc is manufactured with a sheet of material of calibrated width, Nickel, contained in a copper ring case.

## SCOPE

**Use:** protection against possible overpressures of the apparatuses listed below, with regard to the operating conditions for which they have been designed:

- Refrigerating system and heat pump components, for instance: condensers, liquid receivers, evaporators, liquid accumulators, positive displacement compressor discharge, heat exchangers, oil separators, piping. (reference: EN 378-2:2008 Standard)

**Fluids:** the valves can be used with:

- Refrigerant fluids, in the physical state of gas or vapour, belonging to Group 2 according to the definitions of 97/23/EC Directive, Article 9, Point 2.2 (with reference to 67/548/EEC Directive of June 27<sup>th</sup>, 1967)

## MARKING

In conformity with the provisions of Article 15 of 97/23/EC Directive the following information are reported on the bursting disc holder.

- Manufacturer's mark
- EC marking and the identification number of the notified body involved in the production control phase
- Valve model
- Flow section
- Indication of flow direction
- Bursting pressure
- Performance tolerances
- Coincident temperature to bursting pressure
- Production date
- Lot number

## BURSTING DISC DEVICES SELECTION

97/23/EC Directive requires that pressure equipment, in which permissible limits are reasonably likely to be exceeded, shall be fitted with suitable protection devices, for instance safety devices such as bursting disc safety devices. Such devices shall prevent pressure from permanently exceeding the max allowable pressure PS of the equipment they protect. In any case, a short pressure peak limited to 10% of admissible maximum pressure is permitted.

The bursting disc safety device 3070 may be used either as sole pressure relief device or in conjunction with a Castel safety valve (types 3030 e 3060). The combination disc plus valve prevents the refrigerant leakage through the safety valve and the total loss of refrigerant after the disc burst. This combination may be also equipped with a proper pressure switch to detect if the valve has discharged.

The bursting pressure of the safety device 3070 is affected by the operating temperature of fluid contained into the equipment to be protected. The specified bursting pressure  $P_b$ , stamped on the body, is the nominal bursting pressure at the coincident temperature of 22 °C: At higher operating temperatures the nominal bursting pressure is reduced while at lower operating temperatures the nominal bursting pressure is increased. Refer to table 1 for temperature adjustment factors of  $P_b$ .

As to the selection and sizing of the suitable protection device, users shall refer to the specific product and sector standards.

EN ISO 4126-2: 2003 Standard: "Safety devices for protection against excessive pressure – Part 2: Bursting disc safety devices", specifies general requirements for design, manufacturing, inspection, testing, certification, marking, packaging of bursting disc safety devices

EN ISO 4126-3: 2006 Standard: "Safety devices for protection against excessive pressure – Part 3: Safety valves and bursting disc safety devices in combination", harmonized with 97/23/EC Directive, specifies general requirements for design, application and marking for a product assembled from the in-series combination of safety valve and bursting disc safety device.

EN ISO 4126-6: 2003 Standard: "Safety devices for protection against excessive pressure – Part 6: Application, selection and installation of bursting disc safety devices", gives guidance on the application, selection and installation of bursting disc safety devices used to protect pressure equipment from excessive pressure

EN 378-2 : 2008 Standard "Refrigerating systems and heat pumps – safety and environmental requirements – Part 2: Design, construction, testing, marking and documentation", harmonized with 97/23/EC Directive, provides a general outline of the protection devices to be adopted in refrigerating systems and their features (par. 6.2.5). It also indicates the criteria for the selection of the device suitable to the type and sizes of the system component to be protected (par. 6.2.6).

EN 13136:2001/A1:2005 Standard "Refrigerating systems and heat pumps – Pressure relief devices and their associated piping – Methods for calculation", harmonized with 97/23/EC Directive, highlights the possible causes of overpressure in a system and makes available to users the instruments for pressure relief device sizing, among which the safety valves.

### SIZING OF BURSTING DISC DEVICES DESIGNED TO DISCHARGE GAS OR VAPOUR AT CRITICAL FLOW (Ref. . EN ISO 4126-6: 2003)

For the definition of critical flow see the chapter of safety valves series 3030. A bursting disc safety device, which discharges to atmosphere, works in critical flow.

The bursting disc device designed to discharge gas or vapour at critical flow must be sized as follow:

$$A_c = 3,469 \times \frac{Q_{md}}{C \times \alpha} \times \sqrt{\frac{v_o}{p_o}} \quad [mm^2]$$

with:

- $A_c$  = minimum flow area of bursting disc [mm<sup>2</sup>]
- $Q_{md}$  = minimum required discharge capacity of bursting disc [kg/h]
- $\alpha$  = bursting disc coefficient of discharge
- $p_o$  = relieving pressure. [bar abs]
- $v_o$  = specific volume of gas or vapour at relieving conditions  $p_o$  e  $T_o$ , meaning with  $T_o$  fluid temperature at valve inlet, settled by the user or by the designer. [m<sup>3</sup>/kg]
- $C$  = function of isentropic coefficient  $k$ . To calculate  $C$  and to find the values of  $k$  and  $C$  for the more useful refrigerants, see the chapter of safety valves series 3030

EN ISO 4126-6:2003 Standard establishes different values for the coefficient of discharge " $\alpha$ " depending on the nozzle entry configuration where the bursting disc is mounted. The following cases are shown in the aforesaid Standard, Par. C.2.2.1:

- In case of an internally protruding branch/nozzle:  $\alpha = 0,68$
- In case of a flush branch/nozzle whose inlet is not of hydrodynamic configuration:  $\alpha = 0,73$
- In case of a branch/nozzle with rounded or chamfered inlets (hydrodynamic configuration):  $\alpha = 0,80$

Calculation of minimum required discharge capacity of bursting disc safety device is closely linked to the type of system where the valve is installed, with the causes that may arouse the opening of safety device, i.e.:

- External heat sources
- Internal heat sources
- Excessive pressure caused by compressors

For the calculation of minimum required discharge capacity in these three cases see the chapter of safety valves series 3030.

### SIZING OF COMBINATED SAFETY DEVICES DESIGNED TO DISCHARGE GAS OR VAPOUR AT CRITICAL FLOW (Ref. . EN ISO 4126-3: 2006)

The **combination** is an installation which comprises a bursting disc safety device installed within five pipe diameters before the inlet of a safety valve. The combination of a specified safety valve with a bursting disc device is characterized by a combination discharge capacity factor " $F_d$ ". According to EN ISO 4126-3: 2006 Standard the coefficient " $F_d$ " is the ratio of the average of coefficients of discharge " $K_d$ " of combination, determined by the combination tests, to the certified coefficient of discharge " $K_d$ " of the sole safety valve.

As a alternative to testing to determine the " $K_d$ " factor of the combination, the same standard permits the use of a default combination discharge capacity factor of 0,9, value quite lower than the one obtained from testing. Then to size a combination, safety valve /3030 or 3060) with bursting disc safety device (3070), follow the calculation indicated in the chapter of safety valve 3030 , but multiply for 0,9 the certified coefficient of discharge " $K_d$ ".

## INSTALLATION OF BURSTING DISC DEVICES AND COMBINATIONS

**Never expose a 3070 safety device to a negative differential pressure between upstream and downstream (for example equipment internal pressure lower than atmospheric pressure) to avoid possible damage to the disc. For this reason the 3070 safety device must always be used coupled with a shut-off device (for example 3033/44 ball valve), so it is possible to exclude the 3070 device every time it is necessary to make vacuum in the equipment to be protected.**

**When the bursting disc discharges it is necessary to replace all the safety device because 3070 devices are a sealed component with not replaceable bursting disc.**

**Max operating pressure of equipment to be protected shall be no more than 75 % of burst pressure of safety device 3070, to avoid disc damages or leakage. If operating pressure exceeds 85 % of burst pressure, safety device 3070 should be replaced immediately.**

As far as the installation of bursting disc safety devices and combination devices is concerned, the fundamental points listed below shall be taken into account:

- Safety devices shall be installed near an area of the system where vapours or gases are present and there is no fluid turbulence.
- Vessels, joined together with piping rightly selected by the manufacturer and without any stop valve between them, may be considered as only one vessel for the installation of a safety device.
- The union between the combination and the equipment to be protected shall be as short as possible. Furthermore, its passage section shall not be narrower than the valve inlet section. In any case, EN 13136:2001/A1:2005 Standard states that the pressure loss between protected vessel and combination, at discharge capacity, shall not exceed 3% of the setting value, including any accessory mounted on the upstream line.
- In selecting the safety device location, it shall be taken into account that its operation involves the discharge of the refrigerant fluid under pressure, sometimes even at high temperature. Where the risk exists to cause direct injuries to the persons nearby, an exhaust conveying piping shall be provided, which shall be sized in such a way as not to compromise device operation. EN 13136:2001/A1:2005 Standard states that this piping shall not generate, at discharge capacity, a back pressure exceeding 10% of pressure  $p_0$ , for standard type valves, unbalanced.

To calculate the pressure loss either in the upstream line (between vessel and safety valve) or in the downstream line (between safety valve and atmosphere) refer to EN 13136:2001/A1:2005 Standard, Chapter 7.4.

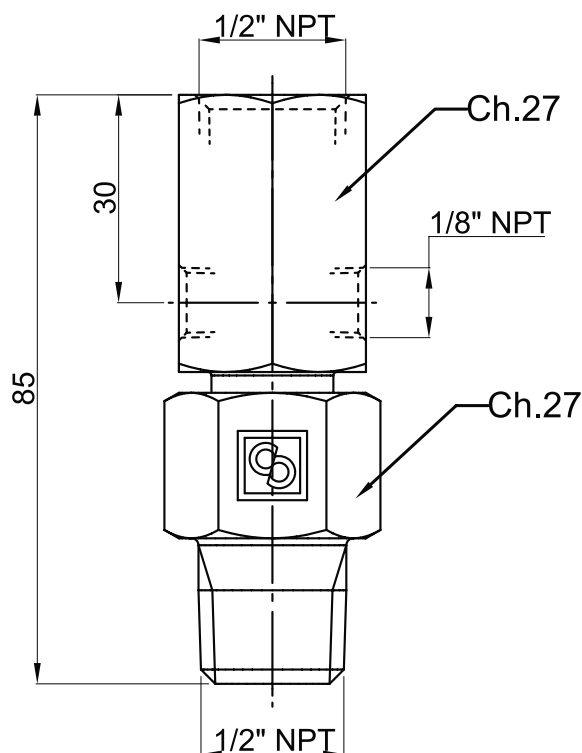

**TABLE 1: General Characteristics of rupture discs 3070**

Catalogue Number		3070/44	
Connections	Inlet male	1/2" NPT	
	Outlet female	1/2" NPT	
	Service	2 x 1/8" NPT	
Inlet connection wrench torque (min/max) [Nm]		21/30	
Flow Diameter [mm]		12	
Flow Section [mm <sup>2</sup> ]		113	
TS [°C]		- 50 / + 150	
Bursting Pressure Pb [bar]		14	
		16	
		21	
		24	
		24,8	
		27,5	
		28	
Pb tolerance	from 14 up to bar	+/- 15 %	
	from 24 up to 28 bar	+/- 10%	
Coincident temperature Ta [°C]		22	
Correction factor of Pb for Ta ≠ 22 °C		-50 °C	1,13
		-35 °C	1,12
		-25 °C	1,10
		-10 °C	1,03
		-0 °C	1,03
		22°C	1,00
		40°C	0,99
		60 °C	0,97
		80 °C	0,95
		100 °C	0,94
150 °C	0,93		
Max operating pressure		75 % Pb	
Risk Category according to PED		IV	





## GENERAL DESCRIPTION

Fusible plugs series 3080/.C and 3082/.C are safety devices according to the definition given in Article 1, Point 2.1.3, 2<sup>nd</sup> dash of 97/23/EC Directive and are the subject of Article 3, Point 1.4 of aforesaid Directive.

According to the definition given in Point 3.6.4 of EN 378-1:2008 Standard, fusible plug is a device containing material that melts at a predetermined temperature and thereby relieving the pressure.

Castel has resolved to classify fusible plugs series 3080/.C and 3082/.C in the Category of Risk I therefore fixing their use, as protection devices, on specific pressure equipments, proper to the same Category of Risk I, in compliance with Annex II, Point 2, of 97/23/EC Directive.

In consequence of this choice, fusible plugs series 3080/.C and 3082/.C **cannot be used**, as sole protection devices, on pressure equipments proper to Categories of Risk higher than first.

## CONSTRUCTION

The body of the fusible plug is an NPT plug drilled with a taper hole. A predetermined quantity of fusible alloy, with checked melting point, is poured inside this hole.

The parts of the fusible plugs are made with the following materials:

- Brass EN 12164 – CW 614N, hot tinned, for the plug
- Eutectic alloy with several components, cadmium free, for the fusible material

## SCOPE

**Use:** the fusible plugs are basically used to protect the components in a refrigerating system or heat pump against possible overpressures, with regard to the operating conditions for which they have been designed, in case of an excessive external heat source, such as fire (point 6.2.6.6 of EN 378-2:2008)

**Fluids:** the fusible plugs can be used with refrigerant fluids belonging to Group 2 according to the definitions of 97/23/EC Directive, Article 9, Point 2.2 (with reference to 67/548/EEC Directive of June 27<sup>th</sup>, 1967).

## MARKING

In conformity with the provisions of Article 15 of 97/23/EC Directive and of Point 7.3.3 of EN 378-2:2008 Standard the following data are reported on the hexagonal nut:

- EC marking
- Manufacturer's logo
- Max allowable pressure PS
- Melting point

## INSTALLATION

If a fusible plug is mounted on a pressure vessel or any other part which it protect **it shall be placed in a section where superheated refrigerant would not affect its correct function.** Fusible plug shall not be covered by thermal insulation. Discharge from fusible plugs shall take place so that persons and property are not endangered by the released refrigerant. (point. 6.2.6.6 of EN 378-2:2008)

EN 378-2:2008 Standard, harmonized with the 97/23/EC Directive, establishes that a fusible plug shall not be used as pressure relief device on vessels containing refrigerants proper to A2, B1, B2, A3 e B3 groups. The same Standard establishes that a fusible plug shall not be used as the sole pressure relief device between a refrigerant containing component and the atmosphere for systems with a refrigerant charge larger than 2,5 kg of group A1 refrigerant (ex. R22; R134a; R404A; R407C; R410A; R507).

## FUSIBLE PLUG SELECTION

97/23/EC Directive requires that pressure equipment, in which permissible limits are reasonably likely to be exceeded, shall be fitted with suitable protection devices, for instance safety devices such as fusible plugs. Such devices shall prevent pressure from permanently exceeding the max allowable pressure PS of the equipment they protect. In any case, a short pressure peak limited to 10% of admissible maximum pressure is permitted.

As to the selection and sizing of the suitable protection device, users shall refer to the specific sector or product standards.

EN 378-2:2008 Standard "Refrigerating systems and heat pumps – safety and environmental requirements – Part 2: Design, construction, testing, marking and documentation"

provides a general outline of the protection devices to be adopted in refrigerating systems and their features (par. 6.2.5). It also indicates the criteria for the selection of the device suitable to the type and sizes of the system component to be protected (par. 6.2.6).

EN 13136:2001/A1:2005 Standard “Refrigerating systems and heat pumps – Pressure relief devices and their associated piping – Methods for calculation”, harmonized with 97/23/EC Directive, highlights the possible causes of overpressure in a system and makes available to users the instruments for pressure relief device sizing, among which the fusible plugs.

### SIZING OF FUSIBLE PLUGS (Ref. EN 13136:2001/A1:2005)

As the fusible plugs discharge to atmosphere, they always work in critical flow (to know the definition of critical flow, see the chapter of safety valves series 3030).

The fusible plugs must be sized as follow:

$$A_c = 3,469 \times \frac{Q_{md}}{C \times K_{dr}} \times \sqrt{\frac{v_o}{p_o}} \quad [\text{mm}^2]$$

with:

- $A_c$  = minimum flow area of fusible plug [mm<sup>2</sup>]
- $Q_{md}$  = minimum required discharge capacity, of refrigerant, of fusible plug [kg/h]
- $K_{dr}$  = derated coefficient of discharge of fusible plug, equal to 0,9 x Kd
- $p_o$  = pressure upstream the fusible plug, inside the equipment to be protected [bar abs]
- $v_o$  = specific volume of gas or vapour at relieving conditions  $p_o$  e  $T_o$ , [m<sup>3</sup>/kg] ( $T_o$  is the fluid temperature at plug inlet, settled by the user or by the designer)

- C = function of isentropic coefficient k (as measured at 25 °C, see Section 7.2.3, EN 13136:2001/A1:2005) calculated from:

$$C = 3,948 \times \sqrt{k \times \frac{2}{k+1} \left( \frac{k+1}{k-1} \right)}$$

To find the values of k and C for the more useful refrigerants, see the chapter of safety valves series 3030. Calculation of minimum required discharge capacity of fusible plug is closely linked to the main cause that may arouse the opening of fusible plug, which is the external heat source.

The minimum required discharge capacity shall be determined by the following:

$$Q_{md} = \frac{3600 \times \varphi \times A_{surf}}{h_{vap}} \quad [\text{kg/h}]$$

with:

- $\varphi$  = density of heat flow rate, it's assumed to be 10 [kW/m<sup>2</sup>]
- $A_{surf}$  = external surface area of the vessel [m<sup>2</sup>]
- $h_{vap}$  = heat of vaporization of liquid at  $p_o$  [kJ/kg]

EN 13136:2001/A1:2005 also establishes that the following values for Kdr shall be the maximum used depending on how the pipe between the vessel and the fusible plug is mounted on the vessel:

- flush or flared connection:  $K_{dr} = 0,70$
- flush or flared connection:  $K_{dr} = 0,55$

TABLE 8: General Characteristics, Dimensions and Weights of fusible plugs 3080 and 3082

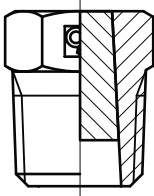
	Catalogue Number	NPT Connections	Flow Diameter [mm]	Flow Section [mm <sup>2</sup> ]	Kd	Melting Point [°C]	Maximum working temperature [°C]	PS [bar] (1)	Hexagonal Key	Wrench Torque min/max [Nm]	Weight [g]	Risk Category according to PED
	3080/1C	1/8"	4,9	18,8	0,91	79	68	42	12	7 / 10	11	I
	3080/2C	1/4"	5,7	25,5					17	10 / 15	23	
	3080/3C	3/8"	8,5	56,7					22	14 / 20	39	
	3080/4C	1/2"	9,3	67,9					22	21 / 30	76	
	3082/1C	1/8"	4,9	18,8		138	127	30	12	7 / 10	11	
	3082/2C	1/4"	5,7	25,5					17	10 / 15	23	
	3082/3C	3/8"	8,5	56,7					22	14 / 20	39	
	3082/4C	1/2"	9,3	67,9					22	21 / 30	76	

(1) : at maximum working temperature



[www.castel.it](http://www.castel.it)



ed. 001-DS-ENG

Castel Srl  
Via Provinciale 2-4 - 20060 Pessano con Bornago - MI