

NORTH AMERICA
5 683 Hines Drive
Ann Arbor, MI 48108
USA
Tel +1 734 585 9500
Fax +1 734 352 3700

EUROPE
2, Avenue Blaise Pascal
38090 Vaulx Milieu
FRANCE
Tel +33 4 74 82 24 00
Fax +33 4 74 82 24 44
sales&marketing@tecumseh.com

MALAYSIA
No. 18, Jalan Sultan Mohamed 4,
Selat Klang Utara,
42000 Port Klang,
Selangor Darul Ehsan
MALAYSIA
Tel +60 3 3176 3886
Fax +60 3 3176 3890

BRAZIL
Rua Ray Wesley Herrick,
700 São Carlos SP, 13565-090
BRAZIL
Tel +55 16 3362 3000
Fax +55 16 3363 7219

INDIA
Balanagar Industrial Township,
Hyderabad, 500 037
INDIA
Tel +91 40 30116993/94

CHINA
Tecumseh Compressor
(Guangzhou) Co., Ltd.
Room 634, Wuzi Building,
201 Guangbao Avenue,
Guangzhou Free Trade Zone,
CHINA
Code: 510730
Tel +86 20 8221 8072
Fax +86 20 8205 7456

For more information
on products by Tecumseh,
please visit our website
www.tecumseh.com



Tecumseh reserves the right to change information contained in this document without notification.
© 2014 Tecumseh Products Company.
All rights reserved.

AJ Series Compressor
catalog EN - 10/2014



actitudes.com - Photos © Tecumseh - © Thinkstock



Tecumseh

Cooling for a Better Tomorrow™

www.tecumseh.com

COMMERCIAL
REFRIGERATION



Series Compressor



IMPROVED
EFFICIENCY

QUIET
OPERATION

ECO-FRIENDLY

M1.3440-1D
K5111742V
F3117-5VDA
C0111601001

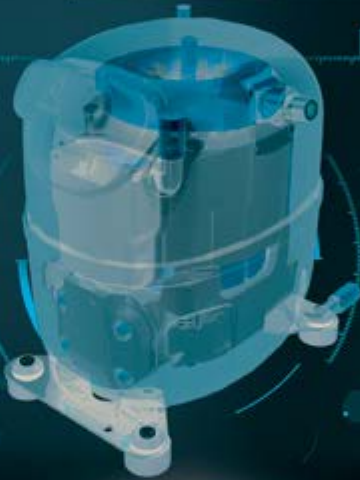

Tecumseh

**OPTIMIZED FOR
HFO & HC REFRIGERANTS**



Built for Today. Ready for Tomorrow.

Cooling for a Better Tomorrow™

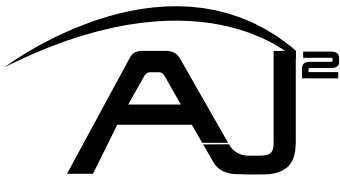

Built for Today. Ready for Tomorrow.

Throughout its history, Tecumseh Products Company has been a leader in providing customers with efficient and reliable products for commercial refrigeration and air conditioning applications. As a result, commercial refrigeration equipment manufacturers, wholesale distributors and service contractors continue to demand the AJ compressor for their specific needs. Following on the path of its predecessor, the AJ² delivers best-in-class efficiency, a wider range, a smaller size envelope, in addition to Tecumseh's standard for reliability.

Key Features and Benefits



SAFE AND EASY ELECTRICAL CONNECTION
Patented moulded plug virtually eliminates wiring errors, reduces installation time and improves enclosure rating.

COMPACTNESS
Redesigned housing lowers height for most of the range. Maximum housing height for models available with new refrigerants will be 268 mm.

ECO-FRIENDLY
Designed for optimum performance with "green" HC (Hydrocarbon) refrigerant R290 (propane) and HFO (R1234yf).

PERFORMANCE
Re-designed valve plate and refrigerant gas handling result in improved compressor efficiency.

LOW NOISE
Redesigned housing and suction/discharge muffler system lowers the overall sound level.

VERSATILE
A variety of suction and discharge connection diameters and types (valve or tube) are offered to facilitate easy installation and serviceability.

PROVEN RELIABILITY
Over 20 million AJ compressors currently in operation in normal to severe duty applications.

WHY A NEW AJ²?

- The AJ compressor range is an established commercial refrigeration standard. Now, Tecumseh is pleased to introduce the next generation AJ, the AJ².
- The AJ² range is ready for tomorrow with HFO and HC refrigerants, while still supporting current refrigerants.
- In order to facilitate HFO introduction, the current AJ R134a range is now dual-refrigerant rated (R1234yf/R134a).

Table of Contents

Introduction	2
Key Features and Benefits	2
Why a New AJ ² ?	2
A Major Innovation – Te-Connect	3
Agency Approvals	3
AJ ² Cooling Capacity Range	4
Compressor Model Nomenclature	4
AJ ² Serial Label	4
50 Hz – Commercial Positive Refrigeration	5
50 Hz – Commercial Negative Refrigeration	5
60 Hz – Commercial Positive Refrigeration	6
60 Hz – Commercial Negative Refrigeration	6
Voltages	7
Rating Point Conditions	7
Electrical Drawings & Motor Types	8
Compressor Tube Connections	9
Compressor Dimensions	9
Packaging	10
What's in a Single Pack?	10
What's in a Multiple Pack?	10
Applications	11
Professional Refrigeration Equipment	11

TECUMSEH INTRODUCES A MAJOR INNOVATION WITH PATENTED Te-Connect

▶ Safe and Secure Connection

- Virtually eliminates wiring errors
- Electrical insulation required for HC refrigerants
- Earth ground integrated

▶ Time is Money

- Connect compressor wiring in less than 2 seconds
- A real Plug-&-Play function
- Requires fewer components to inventory

▶ Added Value

- Tecumseh knowledge
- Unique and powerful connection
- Also useful for OEM and contractors

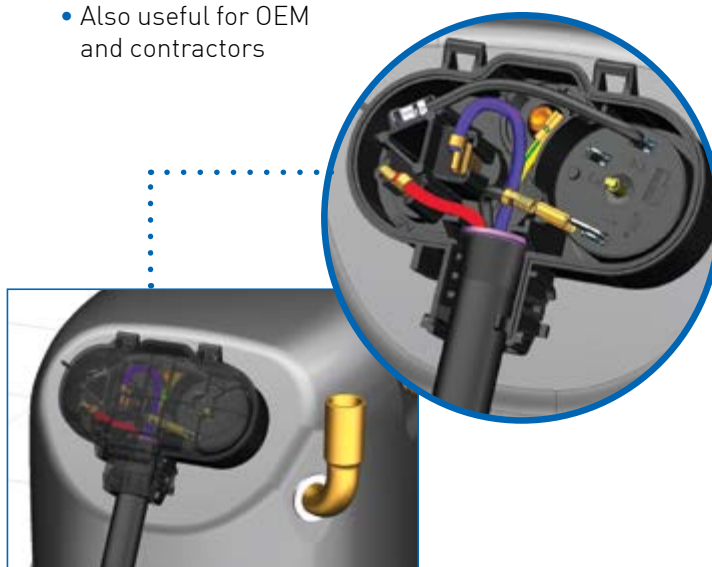

AGENCY APPROVALS



AJ² COOLING CAPACITY RANGE

		Cooling Capacity at 50 Hz									
Application	Btu/h	853	1 705	2 558	3 410	4 263	5 115	5 968	6 820	7 673	8 525
	Watt	250	500	750	1 000	1 250	1 500	1 750	2 000	2 250	2 500
Refrigerant											
HBP	R22										
	R134a										
	R1234yf										
	R404A										
LBP	R290										
	R404A										

COMPRESSOR MODEL NOMENCLATURE

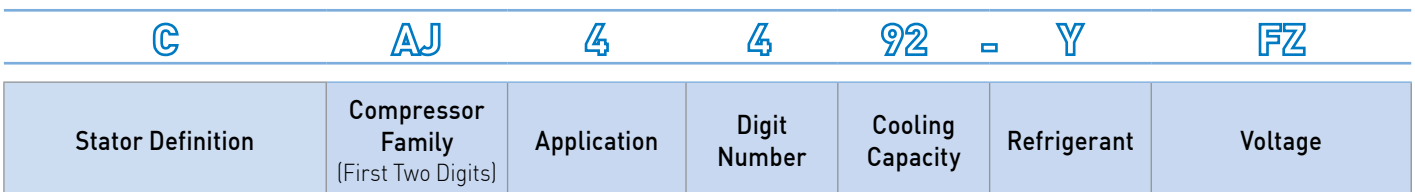

No letter = single-phase low starting torque

C = single-phase high starting torque

T = three-phase

Number of digits composing the cooling capacity

Corresponding to the two first figures of the cooling capacity expressed in BTU/h
In this example total digits 4, with cooling capacity 92 means 9200 BTU/h at 60 Hz

Primary Refrigerants
A = R12
B = R410A
C = R407C
E/T = R22
H = R1234yf
N = R134a/R1234yf
U = R290
Y = R134a
Z = R404A/R507

Primary Application Parameters		
Evap Temperature	Rating Point	Motor Starting Torque
1. Low	-23,3 °C / -10 °F	Normal
2. Low	-23,3 °C / -10 °F	High
3. High	+7,2 °C / +45 °F	Normal
4. High	+7,2 °C / +45 °F	High
5. Air Cond	+7,2 °C / +45 °F	Normal
6. Medium	-6,6 °C / +20 °F	Normal
7. Medium	-6,6 °C / +20 °F	High
8. Air Cond	+9,4 °C / +49 °F	Normal
9. Commercial	-6,6 °C / +20 °F	High
0. Commercial	-6,6 °C / +20 °F	Normal

Approved Voltage
CZ = 208/50/1 - 230/60/1
FZ = 220-240/50/1
GZ = 208-220/50/1
HZ = 208-220/60/1
KZ = 220/50/3 - 220/60/3
TZ = 400/50/3 - 440/60/3
XA = 100/50/1 - 115/60/1
XD = 200/50/1 - 208-230/60/1
XV = 265/60/1
WZ = 2086230/50/1 - 220-230/60/1



NOTE: For explanation of compressor families and codes, contact Tecumseh Products Company.

- 1 Bill of Material Number
- 2 Model Number
- 3 Appropriate Refrigerant
- 4 Serial Number
- 5 Maximum Allowable Pressure
- 6 Minimum and Maximum Temperature
- 7 Test Pressure (1,1 x PS)
- 8 Test Date

50 Hz

COMMERCIAL POSITIVE REFRIGERATION

Model Number	Displacement cm ³	Motor Type	Cooling Capacity (Watt)*								EN 12900 Evap Temp -10 °C		Tube Connections			Weight kg	Height mm
			Evaporating Temperature (°C)								P input (Watt)	COP (W/W)	Suction (mm/ inches)	Discharge (mm/ inches)	Process (mm/ inches)		
			-15	-10	-5	0	+5	+10	+15								
R1234yf HBP	CAJ/TAJ 4492N	25,9	CSIR/TRI	881	1162	1478	1834	2239	2698	3219	701	1,66	12,7 - 1/2"	7,9 - 5/16"	6,35 - 1/4"	20	280
	CAJ/TAJ 4511N	32,7	CSR/TRI	1157	1489	1866	2293	2776	3318	3926	798	1,87	12,7 - 1/2"	7,9 - 5/16"	6,35 - 1/4"	21	280
	CAJ/TAJ4513N	34,45	CSR/TRI	1207	1543	1926	2365	2866	3436	4084	857	1,80	12,7 - 1/2"	7,9 - 5/16"	6,35 - 1/4"	21	280
R134a HBP	CAJ/TAJ 4452Y	15,2	CSIR/TRI	443	607	799	1026	1293	1606	1972	399	1,52	12,7 - 1/2"	6,35 - 1/4"	6,35 - 1/4"	18	268
	CAJ/TAJ 4461Y	18,3	CSIR/TRI	574	756	977	1243	1560	1934	2372	472	1,60	12,7 - 1/2"	6,35 - 1/4"	6,35 - 1/4"	18	268
	CAJ/TAJ 4476Y	22,8	CSIR/TRI	652	888	1163	1484	1856	2287	2781	557	1,59	12,7 - 1/2"	6,35 - 1/4"	6,35 - 1/4"	18	268
	CAJ/TAJ 4492N	25,9	CSIR/TRI	825	1115	1452	1847	2307	2841	3457	649	1,72	12,7 - 1/2"	7,9 - 5/16"	6,35 - 1/4"	20	280
	CAJ/TAJ 4511N	32,7	CSR/TRI	1135	1496	1913	2397	2956	3599	4335	766	1,95	15,9 - 5/8"	7,9 - 5/16"	6,35 - 1/4"	21	280
	CAJ/TAJ 4513N	34,45	CSR/TRI	1214	1591	2028	2533	3118	3791	4562	844	1,89	15,9 - 5/8"	7,9 - 5/16"	6,35 - 1/4"	21	280
R404A HBP	CAJ/TAJ9480Z	15,2	CSR/TRI	920	1159	1434	1752	2117	2535	3013	692	1,67	12,7 - 1/2"	7,9 - 5/16"	6,35 - 1/4"	20	268
	CAJ/TAJ9510Z	18,3	CSR/TRI	1158	1453	1794	2187	2639	3157	3749	844	1,72	15,9 - 5/8"	7,9 - 5/16"	6,35 - 1/4"	21	280
	CAJ/TAJ9513Z	24,2	CSR/TRI	1423	1827	2290	2819	3422	4106	4879	990	1,85	15,9 - 5/8"	7,9 - 5/16"	6,35 - 1/4"	22	280
	CAJ/TAJ4517Z	25,95	CSR/TRI	1648	2070	2552	3104	3736	4459	5283	1122	1,84	15,9 - 5/8"	9,5 - 3/8"	6,35 - 1/4"	22	280
	CAJ/TAJ4519Z	34,45	CSR/TRI	2129	2699	3342	4069	4896	5833	6896	1595	1,69	15,9 - 5/8"	9,5 - 3/8"	6,35 - 1/4"	22	280**
R22 HBP	CAJ/TAJ9480T	15,2	CSR/TRI	838	1062	1329	1644	2015	2450	2956	616	1,72	12,7 / 1/2"	7,9 / 5/16"	6,35 / 1/4"	20	268
	CAJ/TAJ9510T	18,3	CSR/TRI	1052	1328	1653	2034	2480	3000	3601	749	1,77	15,9 / 5/8"	7,9 / 5/16"	6,35 / 1/4"	21	280
	CAJ/TAJ9513T	24,2	CSR/TRI	1342	1716	2157	2674	3278	3979	4787	894	1,92	15,9 / 5/8"	7,9 / 5/16"	6,35 / 1/4"	22	280
	CAJ/TAJ4517E	25,95	CSR/TRI	1541	2009	2527	3096	3712	4373	5077	1004	2,00	15,9 / 5/8"	9,5 / 3/8"	6,35 / 1/4"	22	280
	CAJ/TAJ4519T	34,45	CSR/TRI	2223	2768	3390	4088	4857	5696	6600	1419	1,95	15,9 / 5/8"	9,5 / 3/8"	6,35 / 1/4"	23	280**

* Cooling capacity (Watt) at EN12900 Rating Conditions (+45 °C Condensing Temperature, 0K Sub-cooling, +20 °C Return Gas) - ** Excepted KZ voltage: 292 mm /11,5 inches

COMMERCIAL NEGATIVE REFRIGERATION

Model Number	Displacement cm ³	Motor Type	Cooling Capacity (Watt)*							EN 12900 Evap Temp -35 °C		Tube Connections			Weight kg	Height mm
			Evaporating Temperature (°C)							P abs (Watt)	COP (W/W)	Suction (mm/ inches)	Discharge (mm/ inches)	Process (mm/ inches)		
			-35	-30	-25	-20	-15	-10								
R290 LBP	CAJ2446U	26,2	CSR	628	852	1083	1322	1612	1973	538	1,17	12,7 - 1/2"	7,9 - 5/16"	6,35 - 1/4"	22	268
	CAJ2464U	34,5	CSR	827	1122	1427	1742	2124	2599	709	1,17	12,7 - 1/2"	9,5 - 3/8"	6,35 - 1/4"	23	268
R404A LBP	CAJ/TAJ2428Z	15,2	CSIR/TRI	306	434	589	773	991	1246	368	0,83	12,7 - 1/2"	6,35 - 1/4"	6,35 - 1/4"	19	268
	CAJ/TAJ2432Z	18,3	CSR/TRI	381	542	738	971	1247	1567	417	0,91	12,7 - 1/2"	7,9 - 5/16"	6,35 - 1/4"	20	268
	CAJ2440Z	21	CSR/TRI	463	647	870	1135	1446	1807	499	0,93	12,7 - 1/2"	7,9 - 5/16"	6,35 - 1/4"	21	280
	CAJ/TAJ2446Z	26,2	CSR/TRI	627	859	1133	1451	1819	2241	604	1,04	12,7 - 1/2"	7,9 - 5/16"	6,35 - 1/4"	21	280
	CAJ/TAJ2464Z	34,5	CSR/TRI	828	1116	1459	1864	2336	2882	845	0,98	15,9 - 5/8"	9,5 - 3/8"	6,35 - 1/4"	22	280**

* Cooling capacity (Watt) at EN12900 Rating Conditions (+40 °C Condensing Temperature, 0K Sub-cooling, +20 °C Return Gas) - ** Excepted KZ voltage: 292 mm /11,5 inches

60 Hz

COMMERCIAL POSITIVE REFRIGERATION

	Model Number	Displacement cm ³	Motor Type	Cooling Capacity (Btu/h)*							EN 12900 Evap Temp +14 °F		Tube Connections			Weight lbs	Height inches
				Evaporating Temperature (°F)							P input (Watt)	COP (W/W)	Suction (mm/ inches)	Discharge (mm/ inches)	Process (mm/ inches)		
				+5	+14	+23	+32	+41	+50	+59							
R1234yf HBP	CAJ/TAJ 4492N	25,9	CSIR/TRI	3545	4676	5947	7380	9009	10856	12953	841	1,63	12,7 - 1/2"	7,9 - 5/16"	6,35 - 1/4"	44,1	11,0
	CAJ/TAJ 4511N	32,7	CSR/TRI	4656	5991	7508	9227	11170	13351	15797	958	1,83	12,7 - 1/2"	7,9 - 5/16"	6,35 - 1/4"	46,3	11,0
	CAJ/TAJ4513N	34,45	CSR/TRI	4857	6209	7750	9516	11532	13826	16433	1028	1,77	12,7 - 1/2"	7,9 - 5/16"	6,35 - 1/4"	46,3	11,0
R134a HBP	CAJ/TAJ 4452Y	15,2	CSIR/TRI	1783	2442	3215	4128	5203	6462	7935	479	1,50	12,7 - 1/2"	6,35 - 1/4"	6,35 - 1/4"	39,7	10,6
	CAJ/TAJ 4461Y	18,3	CSIR/TRI	2310	3042	3931	5002	6277	7782	9544	566	1,58	12,7 - 1/2"	6,35 - 1/4"	6,35 - 1/4"	39,7	10,6
	CAJ/TAJ 4476Y	22,8	CSIR/TRI	2624	3573	4680	5971	7468	9202	11190	668	1,57	12,7 - 1/2"	6,35 - 1/4"	6,35 - 1/4"	39,7	10,6
	CAJ/TAJ 4492N	25,9	CSIR/TRI	3320	4487	5843	7432	9283	11432	13910	779	1,69	12,7 - 1/2"	7,9 - 5/16"	6,35 - 1/4"	44,1	11,0
	CAJ/TAJ 4511N	32,7	CSR/TRI	4567	6020	7698	9645	11894	14482	17443	919	1,92	15,9 - 5/8"	7,9 - 5/16"	6,35 - 1/4"	46,3	11,0
	CAJ/TAJ 4513N	34,45	CSR/TRI	4885	6402	8160	10192	12546	15254	18357	1013	1,85	15,9 - 5/8"	7,9 - 5/16"	6,35 - 1/4"	46,3	11,0
R404A HBP	CAJ/TAJ9480Z	15,2	CSR/TRI	3702	4664	5770	7050	8518	10200	12124	830	1,65	12,7 - 1/2"	7,9 - 5/16"	6,35 - 1/4"	44,1	10,6
	CAJ/TAJ9510Z	18,3	CSR/TRI	4660	5847	7219	8800	10619	12703	15085	1013	1,69	15,9 - 5/8"	7,9 - 5/16"	6,35 - 1/4"	46,3	11
	CAJ/TAJ9513Z	24,2	CSR/TRI	5726	7351	9215	11343	13769	16522	19632	1188	1,81	15,9 - 5/8"	7,9 - 5/16"	6,35 - 1/4"	48,5	11
	CAJ/TAJ4517Z	25,95	CSR/TRI	6631	8329	10269	12490	15033	17942	21258	1346	1,81	15,9 - 5/8"	9,5 - 3/8"	6,35 - 1/4"	48,5	11
	CAJ/TAJ4519Z	34,45	CSR/TRI	8567	10860	13448	16373	19701	23471	27748	1914	1,66	15,9 - 5/8"	9,5 - 3/8"	6,35 - 1/4"	48,5	11**
R22 HBP	CAJ/TAJ9480T	15,2	CSR/TRI	3980	4917	6008	7247	8630	10150	11801	781	1,85	12,7 / 1/2"	7,9 / 5/16"	6,35 / 1/4"	44,1	10,6
	CAJ/TAJ9510T	18,3	CSR/TRI	4859	5977	7264	8713	10318	12072	13969	979	1,79	15,9 / 5/8"	7,9 / 5/16"	6,35 / 1/4"	46,3	11
	CAJ/TAJ9513T	24,2	CSR/TRI	5578	7097	8862	10918	13307	16071	19254	1113	1,87	15,9 / 5/8"	7,9 / 5/16"	6,35 / 1/4"	48,5	11
	CAJ/TAJ4517E	25,95	CSR/TRI	6302	8209	10284	12520	14910	17447	20123	1291	1,86	15,9 / 5/8"	9,5 / 3/8"	6,35 / 1/4"	48,5	11
	CAJ/TAJ4519T	34,45	CSR/TRI	9310	11343	13741	16490	19577	22900	26713	1675	1,99	15,9 / 5/8"	9,5 / 3/8"	6,35 / 1/4"	50,7	11**

* Cooling capacity (Btu/h) at EN12900 Rating Conditions (+113 °F Condensing Temperature, 0K Sub-cooling, +68 °F Return Gas) - ** Excepted KZ voltage: 292 mm/11.5 inches

COMMERCIAL NEGATIVE REFRIGERATION

	Model Number	Displacement cm ³	Motor Type	Cooling Capacity (Btu/h)*							EN 12900 Evap Temp -31 °F		Tube Connections			Weight lbs	Height inches
				Evaporating Temperature (°F)							P input (Watt)	COP (W/W)	Suction (mm/ inches)	Discharge (mm/ inches)	Process (mm/ inches)		
				-31	-22	-13	-4	+5	+14								
R290 LBP	CAJ2446U	26,2	CSR	2527	3428	4358	5319	6486	7939	646	1,15	12,7 - 1/2"	7,9 - 5/16"	6,35 - 1/4"	48,5	10,6	
	CAJ2464U	34,5	CSR	3328	4515	5742	7009	8547	10458	851	1,15	12,7 - 1/2"	9,5 - 3/8"	6,35 - 1/4"	50,7	10,6	
R404A LBP	CAJ/TAJ2428Z	15,2	CSIR/TRI	1231	1746	2370	3110	3988	5014	442	0,82	12,7 - 1/2"	6,35 - 1/4"	6,35 - 1/4"	41,9	10,6	
	CAJ/TAJ2432Z	18,3	CSR/TRI	1533	2181	2970	3907	5018	6305	500	0,90	12,7 - 1/2"	7,9 - 5/16"	6,35 - 1/4"	44,1	10,6	
	CAJ2440Z	21	CSR/TRI	1863	2603	3501	4567	5818	7271	599	0,91	12,7 - 1/2"	7,9 - 5/16"	6,35 - 1/4"	46,3	11	
	CAJ/TAJ2446Z	26,2	CSR/TRI	2523	3456	4559	5839	7319	9017	725	1,02	12,7 - 1/2"	7,9 - 5/16"	6,35 - 1/4"	46,3	11	
	CAJ/TAJ2464Z	34,5	CSR/TRI	3332	4491	5871	7500	9400	11597	1014	0,96	15,9 - 5/8"	9,5 - 3/8"	6,35 - 1/4"	48,5	11**	

* Cooling capacity (Btu/h) at EN12900 Rating Conditions (+104 °F Condensing Temperature, 0K Sub-cooling, +68 °F Return Gas) - ** Excepted KZ voltage: 292 mm/11.5 inches

VOLTAGES

50 Hz

MODELS	VOLTAGE AVAILABLE	MODELS	VOLTAGE AVAILABLE	MODELS	VOLTAGE AVAILABLE	MODELS	VOLTAGE AVAILABLE	MODELS	VOLTAGE AVAILABLE
CAJ/TAJ4452Y	XA, FZ, GZ, TZ	CAJ/TAJ9480Z	XA, FZ, GZ, TZ	CAJ/TAJ9480T	XA, FZ, GZ, TZ	CAJ/TAJ2428Z	XA, FZ, GZ, TZ	CAJ2446U	FZ
CAJ/TAJ4461Y	XA, CZ, FZ, GZ, WZ, TZ	CAJ/TAJ9510Z	XA, FZ, GZ, TZ	CAJ/TAJ9510T	XA, FZ, GZ, KZ, TZ	CAJ/TAJ2432Z	XA, FZ, GZ, TZ	CAJ2464U	FZ
CAJ/TAJ4476Y	XA, CZ, FZ, GZ, WZ, KZ	CAJ/TAJ9513Z	XA, FZ, GZ, TZ	CAJ/TAJ9513T	FZ, GZ, TZ	CAJ2440Z	FZ		
CAJ/TAJ4492N	XA, CZ, FZ, GZ, TZ	CAJ/TAJ4517Z	FZ, GZ, KZ, TZ	CAJ/TAJ4517E	FZ, GZ, KZ, TZ	CAJ/TAJ2446Z	XA, FZ, GZ, KZ, TZ		
CAJ/TAJ4511N	CZ, FZ, GZ, TZ	CAJ/TAJ4519Z	FZ, GZ, KZ, TZ	CAJ/TAJ4519T	GZ, KZ, TZ	CAJ/TAJ2464Z	XA, FZ, GZ, KZ, TZ		
CAJ/TAJ4513N	FZ, TZ								

60 Hz

MODELS	VOLTAGE AVAILABLE	MODELS	VOLTAGE AVAILABLE	MODELS	VOLTAGE AVAILABLE	MODELS	VOLTAGE AVAILABLE	MODELS	VOLTAGE AVAILABLE
CAJ/TAJ4452Y	XA, HZ, TZ	CAJ/TAJ9480Z	XA, HZ, TZ	CAJ/TAJ9480T	XA, HZ, TZ	CAJ/TAJ2428Z	XA, HZ, TZ	CAJ2446U	XA
CAJ/TAJ4461Y	XA, CZ, HZ, WZ, TZ	CAJ/TAJ9510Z	XA, HZ, TZ	CAJ/TAJ9510T	XA, HZ, KZ, TZ	CAJ/TAJ2432Z	XA, HZ, TZ	CAJ2464U	XA
CAJ/TAJ4476Y	XA, CZ, HZ, WZ, KZ	CAJ/TAJ9513Z	XA, HZ, TZ	CAJ/TAJ9513T	HZ, TZ	CAJ2440Z	XA		
CAJ/TAJ4492N	XA, CZ, HZ, TZ	CAJ/TAJ4517Z	KZ, HZ, TZ	CAJ/TAJ4517E	HZ, KZ, TZ	CAJ/TAJ2446Z	XA, HZ, KZ, TZ		
CAJ/TAJ4511N	CZ, HZ, TZ	CAJ/TAJ4519Z	KZ, HZ, TZ	CAJ/TAJ4519T	KZ, TZ	CAJ/TAJ2464Z	XA, HZ, KZ, TZ		
CAJ/TAJ4513N	TZ								

CODE	VOLTAGE
CZ	208V 1~ 50 Hz / 230V 1~ 60 Hz
FZ	220 - 240V 1~ 50 Hz
GZ	208 - 220V 1~ 50 Hz
HZ	208 - 220V 1~ 60 Hz

CODE	VOLTAGE
KZ	220V 3~ 50Hz / 220V 3~ 60 Hz
TZ	400V 3~ 50Hz / 440V 3~ 60 Hz
WZ	208-230V~ 50Hz / 220-230V~ 60Hz
XA	100V 1~ 50Hz / 115V 1~ 60Hz

RATING POINT CONDITIONS

		Evaporating Temperature	Condensing Temperature	Return Gaz	Ambiant Temperature	Liquid Temperature
HMP						
ASHRAE 46	°F	23	130	90	90	120
	°C	-5	54,4	32,2	32,2	48,8
EN 12900	°F	14	113	89,6	89,6	113
	°C	-10	45	32	32	45
LBP						
ASHRAE 32	°F	-10	130	90	90	90
	°C	-23,3	54,4	32,2	32,2	32,2
EN 12900	°F	-31	104	89,6	68	104
	°C	-35	40	32	20	40

ELECTRICAL DRAWINGS & MOTOR TYPES

P.S.C.

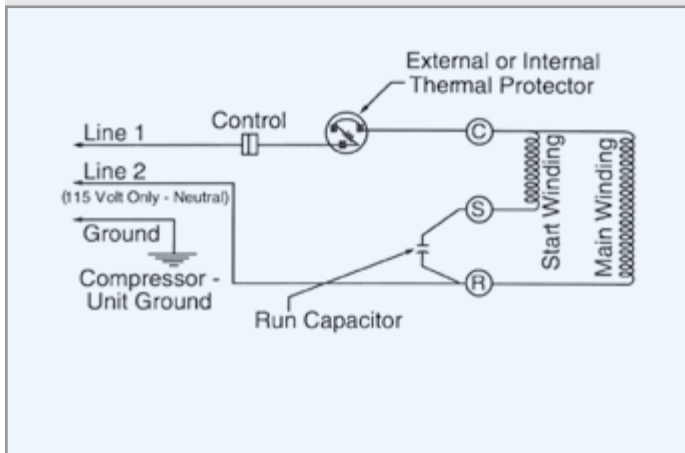

Permanent Split Capacitor (PSC)

A run capacitor is wired in series with the start winding. Both run capacitor and start winding remain in the circuit during start and after motor start-up. This normal starting torque is sufficient for capillary and other self-equalizing system.

Electrical components:

- 1 run capacitor
- 1 external overload protector fitted on the compressor
- 1 earth connection.

C.S.I.R.

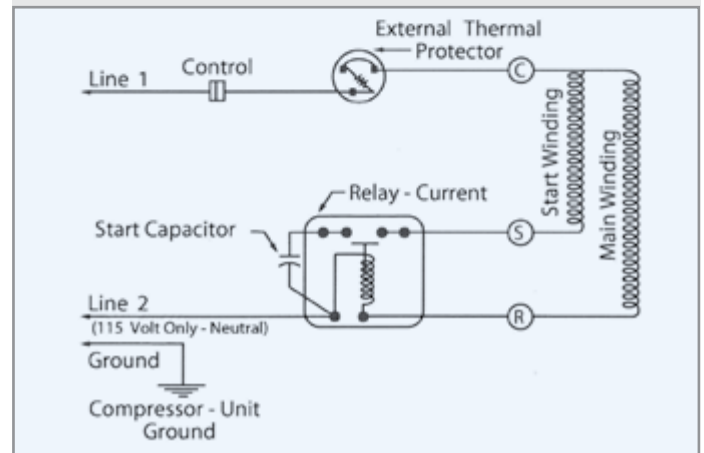

Capacitor Start Induction Run (CSIR)

A start capacitor is included in series with start winding to produce a higher starting torque. During Start-up, the start winding is energized through an electromagnetic relay and start capacitor. This is commonly used on commercial refrigeration systems through 3/4 HP.

Electrical components:

- 1 electromagnetic relay
- 1 external overload protector fitted on the compressor
- 1 start capacitor
- 1 earth connection.

C.S.R.

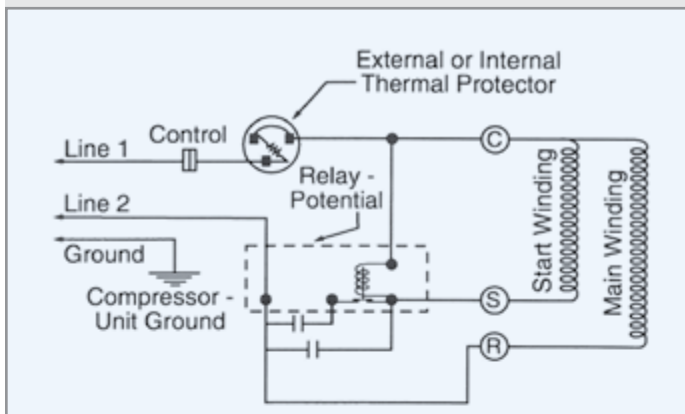

Capacitor Start and Run (CSR)

This motor arrangement uses a start capacitor and a run capacitor in parallel with each other and in series with the motor start winding. A potential relay removes the start capacitor from the circuit after the motor startup. The start winding remains energized with the run capacitor in series while the motor is in operation. This motor has high starting torque, runs efficiently, and is used on many refrigeration applications.

Electrical components:

- 1 external overload protector fitted on the compressor
- 1 electrical box containing:
 - 1 electromagnetic potential relay
 - 1 start capacitor fitted with a discharge resistance
 - 1 terminal block
 - 1 earth connection
 - 1 external run capacitor with fixing brackets
- 1 earth connection.

TRI

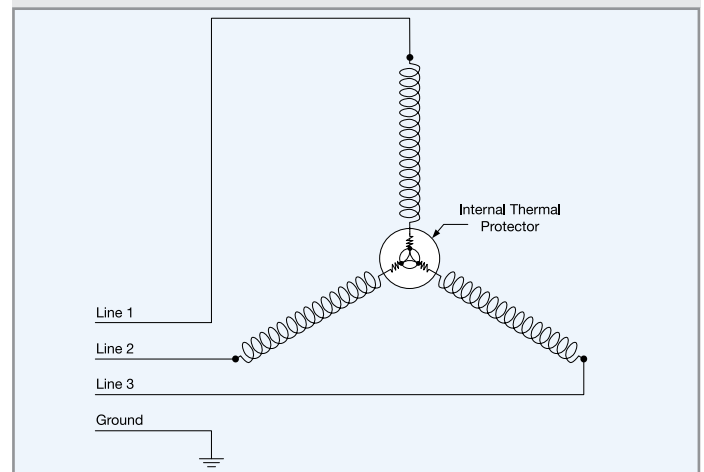

Three Phase Induction Motor (TRI)

The motor is connected to the neutral point of the star connections. Three phase compressors are protected by an internal overload, which cuts out three phases simultaneously in case of too high winding motor temperature and high current.



Electrical box shown not representative of all applications

Compressor Tube Connections



Oil equalization
Optional
(For tandem compressor
and parallel system)

	Nature	Configuration
1	Suction tube	Option*
2	Suction rotalock	Option*

* Choose one of these configurations

Compressor Dimensions

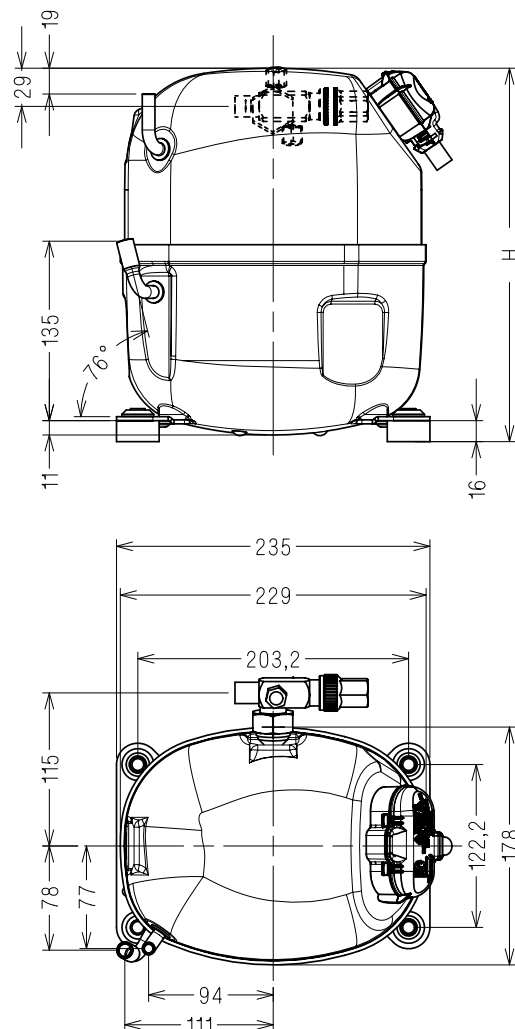

H = 268 mm	H = 280 mm	H = 292 mm
H = 10.6 inches	H = 11 inches	H = 11.5 inches
CAJ/TAJ 4452Y	CAJ/TAJ 4492N	TAJ4519Z-KZ
CAJ/TAJ 4461Y	CAJ/TAJ 4511N	TAJ2464Z-KZ
CAJ/TAJ 4476Y	CAJ/TAJ 4513N	-
CAJ/TAJ9480Z	CAJ/TAJ9510Z	-
CAJ/TAJ2428Z	CAJ/TAJ9513Z	-
CAJ/TAJ2432Z	CAJ/TAJ4517Z	-
CAJ2446U	CAJ/TAJ4519Z	-
CAJ2464U	CAJ2440Z	-
-	CAJ/TAJ2446Z	-
-	CAJ/TAJ2464Z	-

PACKAGING

What's in a Single Pack?



Junior Box

Overload included on single phase only



Te-Connect



Silent-Block

CHECKLIST	
✓	Compressor
✓	Installation Instructions
✓	Junior Box
✓	Te-Connect
✓	Silent-Block
✓	Relay
✓	Potential Relay
✓	Terminal Block
✓	Run Capacitor
✓	Start Capacitor



Installation Instructions

INCLUDED

Example shown not representative of all applications



Start Capacitor

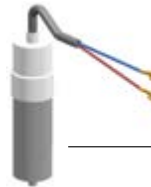

Run Capacitor



Terminal Block



Potential Relay



Relay

What's in a Multiple Pack?

Possible Configurations

- 1 Compressors with electrical box
12 per layer
2 layers per pallet
- 2 PSC or CSR Compressors without electrical box
14 per layer
2 layers per pallet
- 3 Bare Compressors without electrical box
16 per layer
2 layers per pallet

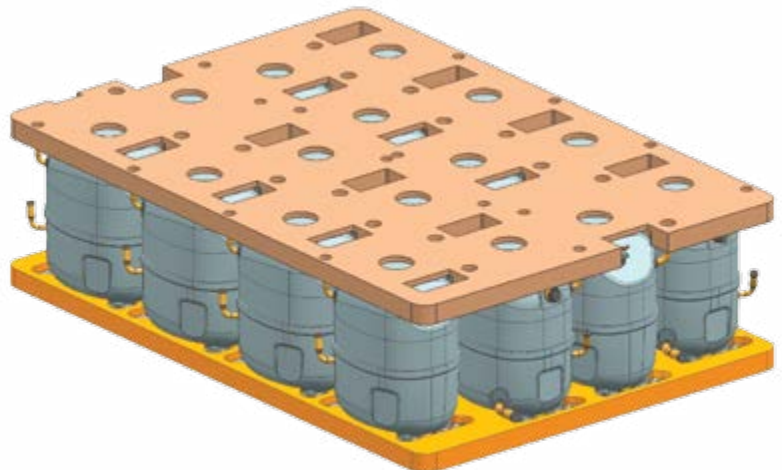

APPLICATIONS

Professional Refrigeration Equipment

