



# Ceiling unit cooler



## MR/MRE commercial range

- The 28 models in the MR range meet the requirements of small storage cold rooms.
- Low depth of only 209 mm enabling optimum use of storage space in the cold room.
- Sturdy and corrosion-resistant unit, coils totally anti-corrosion treated as standard, ABS casing and stainless steel screws.

Heatcraft reserves itself the right to make changes at any time without preliminary notice - Photos non-contractual



*Natural fluids:*  
Glycol water  
CO<sub>2</sub> (R744)\*

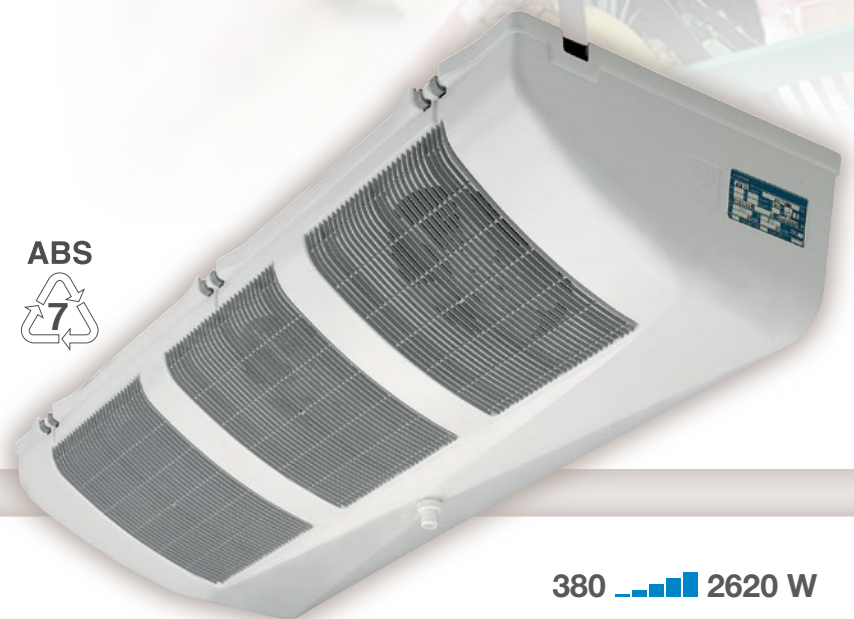

\* Operating pressure 60 bar

380  2620 W



# MR / MRE - Commercial ceiling unit cooler

## Market segments



- Bars - Restaurants - Corner shops - Mini-markets
- Hard Discount - Supermarkets - Hypermarkets

## Description

### Casing

- The ABS recyclable casing guarantees a high quality with regard to:
  - **Sturdyness:** high thermal (at low and high temperatures) and mechanical shock resistance.
  - **Aesthetics:** the design, finish and granulated white casing enable perfect integration of the unit into the surrounding environment.
  - **Hygiene:** no condensate retention zones favouring the development of harmful germs thanks to the casing with rounded corners and no corrosive elements (for example: stainless steel fastening screws).
  - **Safety:** no sharp or cutting edges.

### Ventilation

- The MR and MRE models are equipped with a 50-60 Hz, Ø 200 mm fan with an enclosed motor, class B, impedance protected, permanently lubricated, connected in a junction box (except for MR 75/65) (photo n°1).
- Fan guards compliant with safety standards.

### Coil

- The highly efficient and compact MR range finned coils are designed with corrugated surface aluminium fins (fin spacing 4.23 or 6.35 mm) and internally grooved copper tubes.
- The coils are supplied via Venturi distributors for models MR 160/140 to MR 270/250 and MRE 135/120 to MRE 270/250.
- The entire MR coil has a polyester paint protection coating, particularly important for corrosive environments (photo n°2).

### Defrost

- The electric heating element is fitted in slots under the coil. This layout considerably simplifies maintenance and guarantees homogenous dispersion of heat over the entire coil. This enables perfect defrosting.
- Condensate is collected in an intermediate drain pan then drained through a large condensation drain fitting (Ø 1" G).

## Advantages

### Installation

The expansion valve may be supplied factory pre-fitted (option DMP), as well as fully equipped (option EEC) to help reduce installation time (photo n°3).

### Servicing / Maintenance

The MR range has been designed for easy commissioning, maintenance and cleaning. Casing fitted with polyamide hinges to provide total access to all unit cooler elements (coil, electric fan, defrost heater, connections,...). These hinges also enable removal of the casing.

The electric heating elements are fitted in slots under the coil offering unimpeded front access which considerably simplify maintenance (MRE).

## Designation

# MRE<sup>(1)</sup> 210<sup>(2)</sup> E<sup>(3)</sup>

- (1) **MR** = chill temp. models without defrost  
**MRE** = low temp. models with defrost
- (2) Model
- (3) Fin spacing: **R / E** = 4.23 mm - **L / C** = 6.35 mm

## Certifications

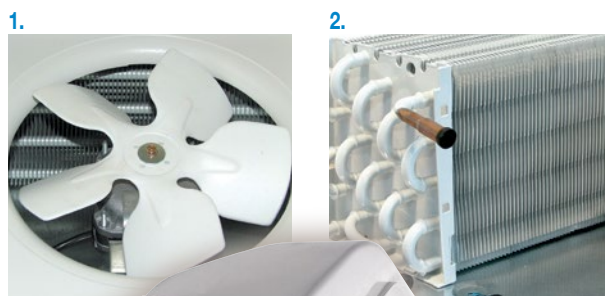

Kit	Factory
-----	---------

## Options

### Coil

Glycol water, coolant (please contact us for details).  
R744 optimization (please contact us for details).

### Defrost

Light electric defrost: MR...R and MR...L.  
For low temperature cold storage rooms with end of defrost thermostat with single-pole, reversing switch at +12°C (±3 K) and delayed fan start up +2°C (±3 K), supplied with a sensor and fastening bracket.

### Fully equipped unit coolers

Expansion valve fitted.  
Fully equipped unit cooler:
 

- Expansion valve fitted.
- Solenoid valve fitted.
- Piping pre-fitted with a ball valve (siphoning function provided by the collector).

	WCO CO2
E1K	E1U THD (MRE)
	DMP EEC

## MR ...

4,23 mm

	MR ... R	75	110	135	160	180	210	270
Capacity R404A (1)	DT1 = 8K - SC 2	W	680	1070	1270	1550	1860	2620
Capacity CO <sub>2</sub> (4)	DT1 = 8K - SC 2	W	598	932	1242	1737	1737	2633
Surface		m <sup>2</sup>	3,35	3,66	6,10	8,04	8,04	13,40
Circuit volume		dm <sup>3</sup>	0,58	0,63	1,05	1,10	1,38	2,30
Air flow		m <sup>3</sup> /h	290	650	580	880	880	1160

## MR ...

6,35 mm

	MR ... L	65	100	120	140	170	190	250
Capacity R404A (1)	DT1 = 8K - SC 2	W	620	890	1180	1370	1680	2440
Capacity CO <sub>2</sub> (4)	DT1 = 8K - SC 2	W	541	782	1127	1564	1564	2392
Capacity W (5)	DT1 = 8K	W	-	-	1220	1150	-	1790
Surface		m <sup>2</sup>	2,32	2,53	4,22	5,56	5,56	9,27
Circuit volume		dm <sup>3</sup>	0,58	0,63	1,05	1,10	1,38	2,30
Air flow		m <sup>3</sup> /h	310	660	620	960	960	1240

Fan 230 V/1/50-60 Hz 1,500 rpm.	Air throw (2)	m	3,0	3,7	3,5	4,1	4,1	4,0	4,5
	Ø 200 mm	Nb	1	2	2	3	3	3	4
	230 V/1/50 Hz	W max	1 x 38	2 x 38	2 x 38	3 x 38	3 x 38	3 x 38	4 x 38
Electric defrost E1K	230 V/1/50 Hz	Nb	1	1	1	1	1	1	1
		W	400	440	730	960	960	1200	1600
		A	1,8	2,0	3,3	4,4	4,4	5,5	7,3
Net weight		kg	3	8	10	15	15	15	20
Dimensions	A	mm	514	784	784	1174	1174	1174	1504
	B	mm	326	596	596	493	493	493	658
Connections R404A	Inlet	Ø ODF *	3/8"-10mm**	3/8"-10mm**	3/8"-10mm**	D 1/2" ***	D 1/2" ***	D 1/2" ***	D 1/2" ***
	Outlet	Ø ODF *	3/8"-10mm	3/8"-10mm	3/8"-10mm	1/2"-12mm	1/2"-12mm	1/2"-12mm	1/2"-12mm

(1) See page 12.

(2) Residual air speed: 0.25 m/s.

(3) Setting of overload protection levels. For air temperatures "ti" other than +20 °C, multiply the currents in relation to 293/(273 + "ti") in order to obtain an approximate current value after the chamber temperature is attained.

(4) Operating pressure 60 bar - Tube diameter to define the order.

(5) Glycol water: Percentage of glycol = 30% - Fluid inlet temp. = -8°C - Fluid outlet temp. = -4°C - Inlet dry temp. = +2°C - Relative humidity = 85%

\* ODF: Female to receive a tube of the same diameter.

\*\* Unions provided for expansion valve to be brazed Ø 1/2" or Ø 12 mm.

\*\*\* Distributor: Ø 1/2" male to be brazed.

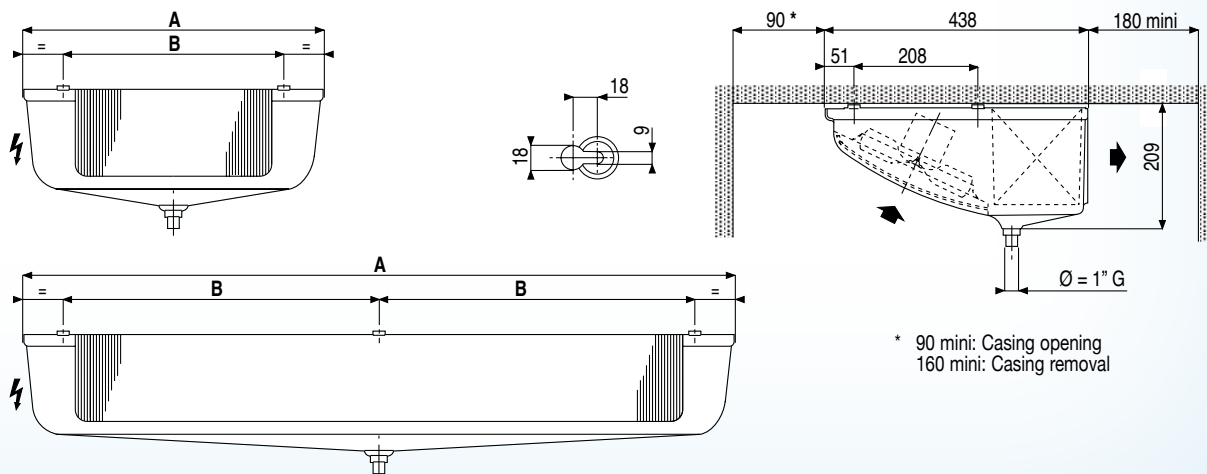
\* 90 mini: Casing opening  
160 mini: Casing removal

WCO

CO<sub>2</sub>

E1K



E1U



THD



DMP



EEC



## MRE ...

4,23 mm

		MRE ... E	75	110	135	160	180	210	270
Capacity R404A (1)	DT1 = 7K - SC 3	W	530	820	1070	1210	1440	1660	2230
	DT1 = 6K - SC 4	W	420	640	840	960	1140	1320	1780
Capacity CO <sub>2</sub> (4)	DT1 = 7K - SC 3	W	515	798	1061	1470	1470	1649	2195
	DT1 = 6K - SC 4	W	414	636	859	1202	1202	1353	1788
Surface		m <sup>2</sup>	3,35	3,66	6,10	8,04	8,04	10,05	13,40
Circuit volume		dm <sup>3</sup>	0,58	0,63	1,05	1,10	1,38	1,73	2,30
Air flow		m <sup>3</sup> /h	290	650	580	880	880	870	1160

## MRE ...

6,35 mm

		MRE ... C	65	100	120	140	170	190	250
Capacity R404A (1)	DT1 = 7K - SC 3	W	480	670	950	1080	1310	1510	2030
	DT1 = 6K - SC 4	W	380	540	760	850	1040	1210	1630
Capacity CO <sub>2</sub> (4)	DT1 = 7K - SC 3	W	462	672	956	1323	1323	1502	1995
	DT1 = 6K - SC 4	W	374	535	778	1081	1081	1232	1636
Surface		m <sup>2</sup>	2,32	2,53	4,22	5,56	5,56	6,96	9,27
Circuit volume		dm <sup>3</sup>	0,58	0,63	1,05	1,10	1,38	1,73	2,30
Air flow		m <sup>3</sup> /h	310	660	620	960	960	930	1240

Fan 230 V/1/50-60 Hz 1,500 rpm.	Air throw (2)	m	3,0	3,7	3,5	4,1	4,1	4,0	4,5
	Ø 200 mm	Nb	1	2	2	3	3	3	4
	230 V/1/50 Hz	W max	1 x 38	2 x 38	2 x 38	3 x 38	3 x 38	3 x 38	4 x 38
		A max (3)	1 x 0,24	2 x 0,24	2 x 0,24	3 X 0,24	3 X 0,24	3 x 0,24	4 x 0,24
Electric defrost 230 V/1/50 Hz	Nb	1	1	1	1	1	1	1	
	W	400	440	730	960	960	1200	1600	
	A	1,8	2,0	3,3	4,4	4,4	5,5	7,3	
Net weight		kg	3	8	10	15	15	15	20
Dimensions	A	mm	514	784	784	1174	1174	1174	1504
	B	mm	326	596	596	493	493	493	658
Connections R404A	Inlet	Ø ODF *	3/8"-10mm**	3/8"-10mm**	D 1/2" ***	D 1/2" ***	D 1/2" ***	D 1/2" ***	D 1/2" ***
	Outlet	Ø ODF *	3/8"-10mm	3/8"-10mm	1/2"-12mm	1/2"-12mm	1/2"-12mm	5/8"-16mm	3/4"-18mm

(1) See page 12.

(2) Residual air speed: 0.25 m/s.

(3) Setting of overload protection levels. For air temperatures "ti" other than +20 °C, multiply the currents in relation to 293/(273 + "ti") in order to obtain an approximate current value after the chamber temperature is attained.

(4) Operating pressure 60 bar - Tube diameter to define the order.

\* ODF: Female to receive a tube of the same diameter.

\*\* Unions provided for expansion valve to be brazed Ø 1/2" or Ø 12 mm.

\*\*\* Distributor: Ø 1/2" male to be brazed.

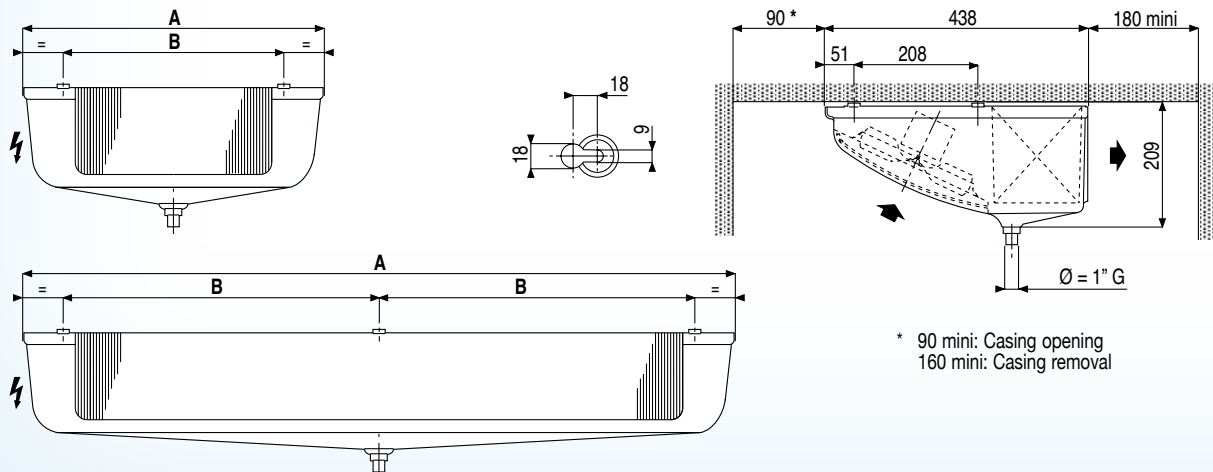

WCO

CO<sub>2</sub>

E1K

E1U

THD

DMP

EEC

-

+

-

-

0

0

0