

MAKING MODERN LIVING POSSIBLE

Danfoss



R600a

Danfoss Compressors

220-240 V • 50 Hz & 60 Hz

REFRIGERATION &
AIR CONDITIONING DIVISION

Quick reference

Level	Application	Compressor	Code number	EN 12900 (CECOMAF) Capacity [W]								EN 12900 (CECOMAF) at LBP rating point -25°C / 55°C			ASHRAE subcooled at LBP rating point -23.3°C / 5			
				Evaporating temperature [°C]								Cooling Capacity	COP without RC	COP with RC	Cooling Capacity		COP without RC	
				-35	-30	-20	-15	-10	-5	0	5				[W]	[kcal/h]	[W/W]	[kcal/Wh]
Energy-optimized	1.	PLE35K	101H0360			38	52	68	87	109		27		0.68	38	33		
	3.	TLES4KK.3	102H4438	19	29	57	75	96				42	0.90		57	49	1.18	1.02
		TLES4.8KK.3	102H4538	28	40	73	94	119				55	1.00		74	65	1.30	1.12
		TLES5.7KK.3	102H4638	36	50	89	114	144				68	1.02		91	79	1.32	1.14
	4.	TLES6.5KK.3	102H4738	45	61	105	134	168				81	1.02		108	94	1.31	1.13
		TLES7.5KK.3	102H4838	53	71	122	155	194				94	1.02	1.07	126	108	1.32	1.14
		TLES8.7KK.3	102H4938	62	83	143	181	228				110	1.03	1.08	147	126	1.33	1.14
		TLES10KK.3	102H4038	73	97	162	205	255				126	0.98	1.06	168	145	1.26	1.08
		NLE8.8KK.4	105H6800	63	84	141	179	223				110	1.18	1.22	147	127	1.51	1.30
		NLE10KK.4	105H6867	74	98	164	207	257				128	1.19	1.23	170	151	1.51	1.30
		NLE11KK.4	105H6952	82	109	184	232	290				143	1.19	1.22	191	165	1.52	1.31
		NLE13KK.4	105H6959	99	131	217	274	340				170	1.18	1.23	226	194	1.50	1.29
NLE15KK.4		105H6968	110	146	243	307	382				190	1.20	1.25	253	213	1.53	1.32	
High Energy-optimized	3.	TLY4 KK.3	102H4442	19	29	57	74	95				42	0.96	0.99	57	49	1.26	1.08
		TLY4.8KK.3	102H4542	28	40	73	94	119				55	1.04	1.06	74	65	1.35	1.16
		TLY5.7KK.3	102H4642	36	51	89	114	144				68	1.03	1.06	91	79	1.33	1.15
		TLY6.5KK.3	102H4742	46	62	106	135	170				82	1.10	1.14	110	94	1.42	1.22
		TLY7.5KK.3	102H4842	53	71	122	155	194				94	1.09	1.14	126	108	1.41	1.22
		TLY8.7KK.3	102H4942	65	86	144	182	227				112	1.12	1.16	149	126	1.44	1.24
		TLY10KK.3	102H4042	74	98	164	208	260				128	1.15	1.21	170	146	1.47	1.27
		TLX4KK.3	102H4447	21	32	59	76	95				45		1.15 ³⁾	60	52		
		TLX4.8KK.3	102H4547	29	42	74	94	117				57		1.23 ³⁾	77	66		
		TLX5.7KK.3	102H4647	37	52	91	115	143				70		1.28 ³⁾	93	80		
	4.	TLX6.5KK.3	102H4747	46	63	106	133	165				83		1.30 ³⁾	110	95		
		TLX7.5KK.3	102H4847	55	75	125	157	195				98		1.32 ³⁾	130	112		
		TLX8.7KK.3	102H4947	65	88	146	184	227				115		1.31 ³⁾	152	131		
		TLX4KK.4	102H4449					94				46		1.26 ³⁾	61	53		
		TLX4.8KK.4	102H4532	32				124				58		1.32 ³⁾	78	67		
		TLX10KK.4	102H4040	76				265				132		1.30 ³⁾	175	150		
		NLX8.8KK	105H6874	60	83	144	182	227				111		1.35	148	127		
		NLX10KK	105H6871	74	100	169	215	269				131		1.36	174	150		
		NLX11KK	105H6984	84	112	189	240	300				147		1.36	195	168		
		NLX13KK	105H6983	98	133	223	282	350				174		1.36	231	199		
NLX15KK	105H6981	110	147	249	317	397				193		1.34	257	221				
2.	NLX8.0KK.2	105H6010	52	73	130	167	210				99		1.47 ³⁾	133	115			
	NLX8.8KK.2	105H6011	62	85	147	187	234				113		1.49 ³⁾	151	130			
	NLX10KK.2	105H6101	75	101	171	217	271				133		1.49 ³⁾	178	153			
	NLX11KK.2	105H6971	86	115	192	242	301				150		1.49 ³⁾	200	172			
	NLX13KK.2	105H6976	95	129	219	277	345				170		1.49 ³⁾	227	196			
	NLX15KK.2	105H6977	110	147	245	309	384				192		1.48 ³⁾	255	220			
Tropical	1.	TLES4KTK	102H4436	18	28	55	74	96	123	154		40	0.83	0.84	54	47	1.09	0.94
		TLES5KTK	102H4536	28	41	76	99	126	159	196		57	0.93	0.95	77	66	1.21	1.04
		TLES6KTK	102H4636	31	48	87	112	140				66	0.95	0.97	88	76	1.22	1.05
		TLES7KTK	102H4736	40	57	101	130	163				77	0.95	0.97	103	89	1.22	1.05
		TLES8KTK	102H4836	48	66	116	149	188				89	0.95	0.97	119	103	1.21	1.04
		NLE9KTK	105H6848	54	74	128	166	211				98	1.03	1.05	131	112	1.32	1.13
		NLE11KTK	105H6948	73	98	162	206	261				127	1.03	1.05	167	144	1.31	1.13
		NLE15KTK	105H6946	93	128	219	280	351				169	1.00	1.02	225	194	1.27	1.10
	2.	NLE15KTK.2	105H6966	103	140	239	305	383				184	1.15		245	211	1.45	1.25

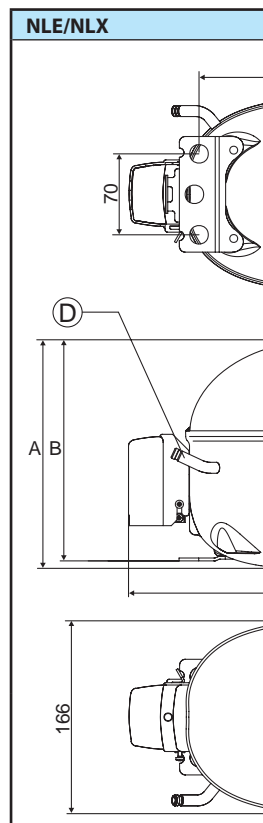
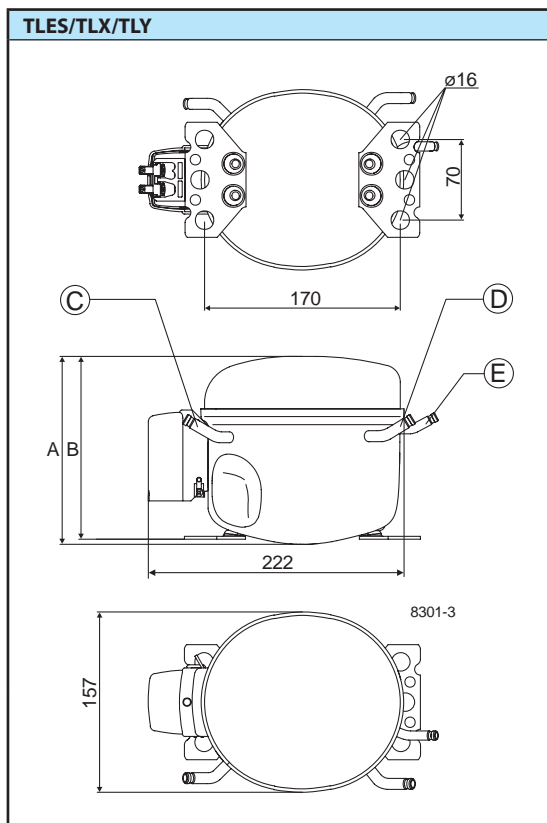
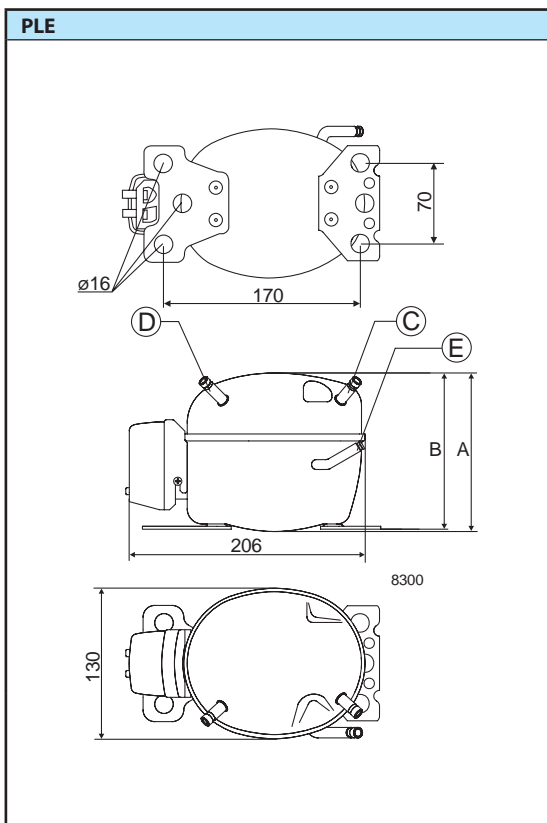

Subcooled at t = -23.3°C / 54.4°C			Displacement [cm³]	Recommended compressor cooling at ambient temperature			Voltage and frequencies	Electrical Equipment						Compressor		
COP without RC		COP with RC		32°C	38°C	43°C		LST (RSIR)		LST (RSCR)		Run capacitor (RC)			Cord relief	Cover
[kcal/Wh]	[W/W]							[kcal/Wh]	PTC Starting device without RC connector		PTC Starting device with RC connector		1) optional 2) compulsory			
								spades		spades		spades				
			4.8 mm	6.3 mm	4.8 mm	6.3 mm	4.8 mm	6.3 mm								
	0.90	0.77	3.00	S*	S*		1			103N0021	103N0016	117-7119 ²⁾	117-7117 ²⁾	103N0491	103N1010	PLE35K
1.02			4.01	S	S	S	1	103N0018	103N0011	103N0021	103N0016	117-7119 ¹⁾	117-7117 ¹⁾	103N2010	103N1010	TLES4.8KK.3
1.12			4.78	S	S	S	1	103N0018	103N0011	103N0021	103N0016	117-7119 ¹⁾	117-7117 ¹⁾	103N2010	103N1010	TLES4.8KK.3
1.14			5.70	S	S	S	1	103N0018	103N0011	103N0021	103N0016	117-7119 ¹⁾	117-7117 ¹⁾	103N2010	103N1010	TLES5.7KK.3
1.13			6.49	S	S	S	1	103N0018	103N0011	103N0021	103N0016	117-7119 ¹⁾	117-7117 ¹⁾	103N2010	103N1010	TLES6.5KK.3
1.14	1.38	1.19	7.48	S	S	S	1	103N0018	103N0011	103N0021	103N0016	117-7119 ¹⁾	117-7117 ¹⁾	103N2010	103N1010	TLES7.5KK.3
1.14	1.39	1.19	8.67	S	S	S	1	103N0018	103N0011	103N0021	103N0016	117-7119 ¹⁾	117-7117 ¹⁾	103N2010	103N1010	TLES7.5KK.3
1.08	1.36	1.17	10.13	S	S	S	1	103N0018	103N0011	103N0021	103N0016	117-7119 ¹⁾	117-7117 ¹⁾	103N2010	103N1010	TLES10KK.3
1.30	1.56	1.34	8.76	S	S	S	1	103N0018	103N0011	103N0021	103N0016	117-7119 ¹⁾	117-7117 ¹⁾	103N2010	103N1010	NLE8.8KK.4
1.30	1.57	1.35	10.09	S	S	S	1	103N0018	103N0011	103N0021	103N0016	117-7119 ¹⁾	117-7117 ¹⁾	103N2010	103N1010	NLE10KK.4
1.31	1.56	1.34	11.15	S	S	S	1	103N0018	103N0011	103N0021	103N0016	117-7119 ¹⁾	117-7117 ¹⁾	103N2010	103N1010	NLE11KK.4
1.29	1.57	1.35	13.25	S	S	S	1	103N0018	103N0011	103N0021	103N0016	117-7119 ¹⁾	117-7117 ¹⁾	103N2010	103N1010	NLE13KK.4
1.32	1.59	1.37	14.65	S	S	S	1	103N0018	103N0011	103N0021	103N0016	117-7119 ¹⁾	117-7117 ¹⁾	103N2010	103N1010	NLE15KK.4
1.08	1.29	1.11	4.01	S	S	S	1	103N0018	103N0011	103N0021	103N0016	117-7119 ¹⁾	117-7117 ¹⁾	103N2010	103N1010	TLY4 KK.3
1.16	1.37	1.18	4.78	S	S	S	1	103N0018	103N0011	103N0021	103N0016	117-7119 ¹⁾	117-7117 ¹⁾	103N2010	103N1010	TLY4.8KK.3
1.15	1.37	1.18	5.70	S	S	S	1	103N0018	103N0011	103N0021	103N0016	117-7119 ¹⁾	117-7117 ¹⁾	103N2010	103N1010	TLY5.7KK.3
1.22	1.47	1.27	6.49	S	S	S	1	103N0018	103N0011	103N0021	103N0016	117-7119 ¹⁾	117-7117 ¹⁾	103N2010	103N1010	TLY6.5KK.3
1.22	1.47	1.27	7.48	S	S	S	1	103N0018	103N0011	103N0021	103N0016	117-7119 ¹⁾	117-7117 ¹⁾	103N2010	103N1010	TLY7.5KK.3
1.24	1.49	1.28	8.67	S	S	S	1	103N0018	103N0011	103N0021	103N0016	117-7119 ¹⁾	117-7117 ¹⁾	103N2010	103N1010	TLY8.7KK.3
1.27	1.55	1.33	10.13	S	S	S	1	103N0018	103N0011	103N0021	103N0016	117-7119 ¹⁾	117-7117 ¹⁾	103N2010	103N1010	TLY10KK.3
	1.48 ³⁾	1.28 ³⁾	4.01	S*	S*	S*	1			103N0050	103N0016	117-7119 ²⁾	117-7117 ²⁾	103N2010	103N1010	TLX4KK.3
	1.58 ³⁾	1.36 ³⁾	4.78	S*	S*	S*	1			103N0050	103N0016	117-7132 ²⁾	117-7131 ²⁾	103N2010	103N1010	TLX4.8KK.3
	1.63 ³⁾	1.40 ³⁾	5.70	S*	S*	S*	1			103N0050	103N0016	117-7119 ²⁾	117-7117 ²⁾	103N2010	103N1010	TLX5.7KK.3
	1.65 ³⁾	1.42 ³⁾	6.49	S*	S*	S*	1			103N0050	103N0016	117-7119 ²⁾	117-7117 ²⁾	103N2010	103N1010	TLX6.5KK.3
	1.68 ³⁾	1.44 ³⁾	7.48	S*	S*	S*	1			103N0050	103N0016	117-7132 ²⁾	117-7131 ²⁾	103N2010	103N1010	TLX7.5KK.3
	1.66 ³⁾	1.43 ³⁾	8.67	S*	S*	S*	1			103N0050	103N0016	117-7119 ²⁾	117-7117 ²⁾	103N2010	103N1010	TLX8.7KK.3
	1.62 ³⁾	1.39 ³⁾	4.01	S*	S*	S*	1			103N0050	103N0016	117-7136 ²⁾	117-7136 ²⁾	103N2010	103N1010	TLX8.7KK.4
	1.68 ³⁾	1.44 ³⁾	4.78	S*	S*	S*	1			103N0050	103N0016		117-7136 ²⁾	103N2010	103N1010	TLX4.8KK.4
	1.65 ³⁾	1.42 ³⁾	10.13	S*	S*	S*	1			103N0050	103N0016		117-7139 ²⁾	103N2010	103N1010	TLX10KK.4
	1.72	1.48	8.76	S*	S*	S*	1			103N0021	103N0016	117-7119 ²⁾	117-7117 ²⁾	103N2010	103N1010	NLX8.8KK
	1.72	1.48	10.09	S*	S*	S*	1			103N0021	103N0016	117-7119 ²⁾	117-7117 ²⁾	103N2010	103N1010	NLX10KK
	1.73	1.49	11.15	S*	S*	S*	1			103N0021	103N0016	117-7119 ²⁾	117-7117 ²⁾	103N2010	103N1010	NLX11KK
	1.72	1.48	13.25	S*	S*	S*	1			103N0021	103N0016	117-7119 ²⁾	117-7117 ²⁾	103N2010	103N1010	NLX13KK
	1.70	1.46	14.65	S*	S*	S*	1			103N0021	103N0016	117-7129 ²⁾	117-7130 ²⁾	103N2010	103N1010	NLX15KK
	1.88 ³⁾	1.62 ³⁾	8.05	S*	S*	S*	1			103N0050	103N0016	117-7132 ²⁾	117-7132 ²⁾	103N2010	103N1010	NLX8.0KK.2
	1.89 ³⁾	1.63 ³⁾	8.76	S*	S*	S*	1			103N0050	103N0016	117-7136 ²⁾		103N2010	103N1010	NLX8.8KK.2
	1.89 ³⁾	1.63 ³⁾	10.09	S*	S*	S*	1			103N0050	103N0016	117-7136 ²⁾		103N2010	103N1010	NLX10KK.2
	1.89 ³⁾	1.63 ³⁾	11.15	S*	S*	S*	1			103N0050	103N0016	117-7136 ²⁾		103N2010	103N1010	NLX11KK.2
	1.89 ³⁾	1.63 ³⁾	13.25	S*	S*	S*	1			103N0050	103N0016	117-7132 ²⁾		103N2010	103N1010	NLX13KK.2
	1.88 ³⁾	1.62 ³⁾	14.65	S*	S*	S*	1			103N0050	103N0016	117-7119 ²⁾	117-7117 ²⁾	103N2010	103N1010	NLX15KK.2
0.94	1.10	0.95	3.86	S	S	S	2	103N0018	103N0011	103N0021	103N0016	117-7119 ¹⁾	117-7117 ¹⁾	103N2010	103N1010	TLES4KTK
1.04	1.23	1.06	5.08	S	S	S	2	103N0018	103N0011	103N0021	103N0016	117-7119 ¹⁾	117-7117 ¹⁾	103N2010	103N1010	TLES5KTK
1.05	1.24	1.07	5.70	S	S	S	2	103N0018	103N0011	103N0021	103N0016	117-7119 ¹⁾	117-7117 ¹⁾	103N2010	103N1010	TLES6KTK
1.05	1.24	1.07	6.49	S	S	S	2	103N0018	103N0011	103N0021	103N0016	117-7119 ¹⁾	117-7117 ¹⁾	103N2010	103N1010	TLES7KTK
1.04	1.23	1.06	7.76	S	S	S	2	103N0018	103N0011	103N0021	103N0016	117-7119 ¹⁾	117-7117 ¹⁾	103N2010	103N1010	TLES8KTK
1.13	1.35	1.15	8.35	S	S	S	2/3	103N0018	103N0011	103N0021	103N0016	117-7119 ¹⁾	117-7117 ¹⁾	103N2010	103N1010	NLE9KTK
1.13	1.34	1.15	11.15	S	S	S**	2/3	103N0018	103N0011	103N0021	103N0016	117-7119 ¹⁾	117-7117 ¹⁾	103N2010	103N1010	NLE11KTK
1.10	1.30	1.12	14.65	S	S	F ₁	2	103N0018	103N0011	103N0021	103N0016	117-7119 ¹⁾	117-7117 ¹⁾	103N2010	103N1010	NLE15KTK
1.25			14.65	S	S	S	2	103N0018	103N0011	103N0021	103N0016	117-7119 ¹⁾	117-7117 ¹⁾	103N2010	103N1010	NLE15KTK.2

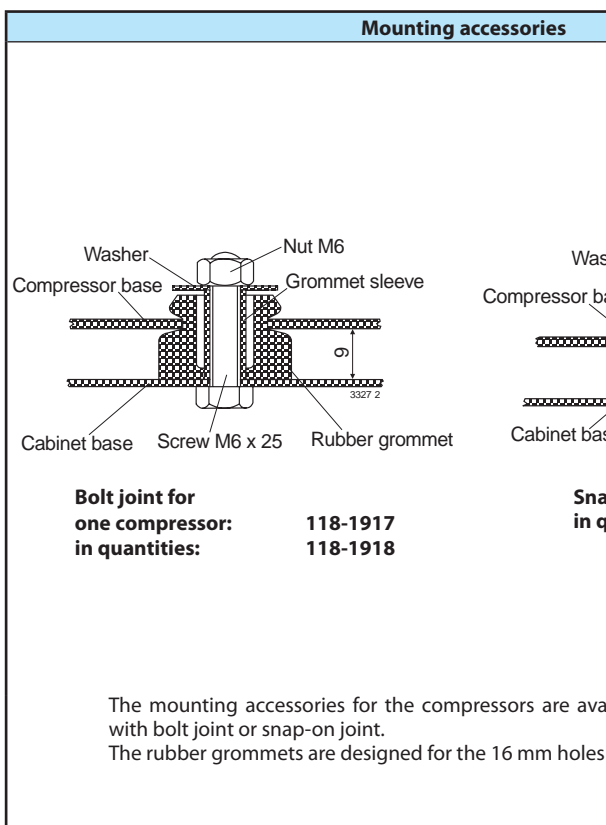
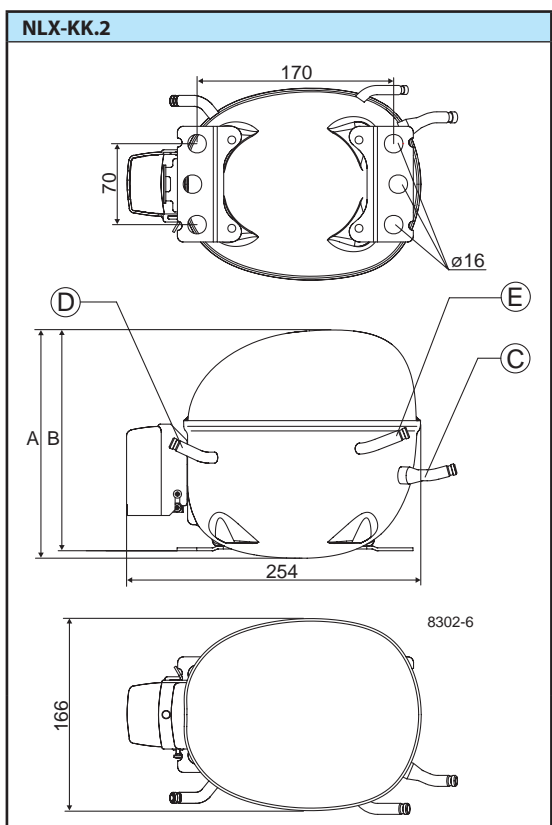
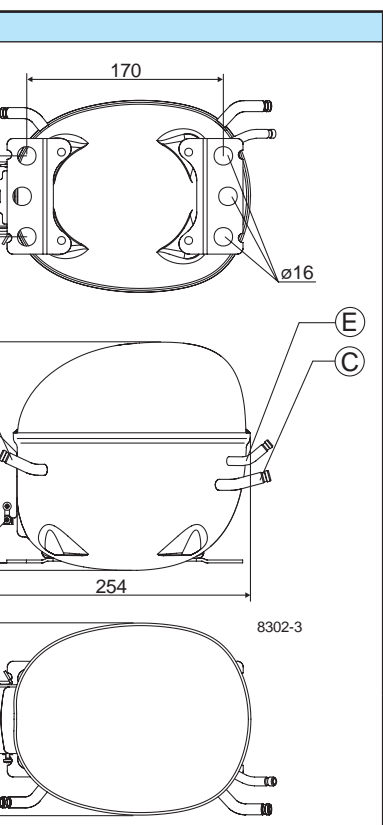

Hermetic Compressors R600a • 220-240 V • 50 Hz & 60 Hz

Applications

LBP: Low Back Pressure
MBP: Medium Back Pressure

Motor types

RSIR: Resistant Start Induction Run
RSCR: Resistant Start Capacitor Run

Starting devices

LST: Low Starting Torque
 LST is used with capillary tube control and pressure equalizing. (Pressure equalizing may exceed 10 minutes). The PTC starting device requires 5 minutes cooling before each start.

Note: To fulfil the requirements of EN 60355-2-34 the protection screen 103N0476 must be applied to the PTC starting device.

Electrical Equipment

- 1) Run capacitor optional
- 2) Run capacitor compulsory
- 3) COP values with ePTC

Run capacitors (RC):

117-7117: 4 µF
 117-7119: 4 µF
 117-7129: 5 µF
 117-7130: 5 µF
 117-7131: 3 µF
 117-7132: 3 µF
 117-7136: 2 µF
 117-7139: 2.5 µF

Test conditions EN 12900 (CECOMAF)

Application **R600a**
 Condensing temperature 55°C
 Ambient temperature 32°C
 Suction gas temperature 32°C
 Liquid temperature 55°C
 220 V / 50 Hz

Test conditions ASHRAE

Application **R600a**
 Condensing temperature 54.4°C
 Ambient temperature 32°C
 Suction gas temperature 32°C
 Liquid temperature 32°C
 220 V / 50 Hz

Compressor cooling

S = Static cooling normally sufficient
 O = Oil cooling
 F₁ = Fan cooling 1.5 m/s
 (compressor compartment temp. equal to ambient temperature)
 F₂ = Fan cooling 3.0 m/s necessary
 * = Run capacitor compulsory
 ** = Run capacitor compulsory in 43°C ambient temp. at 60 Hz

Voltages and frequencies

1 = 198-254 V, 50 Hz
 2 = 187-254 V, 50 Hz
 3 = 198-254 V, 60 Hz, LBP, F₁
 4 = 198-254 V, 50-60 Hz

○ = preliminary data

Model designation

Compressor design	Optimization level	Compressor size	Application range	Start characteristics	Generation
PL	Blank Standard energy level	Nominal displacement in cm ³	K R600a LBP/(MBP)	Blank => universal (principal rule)	Blank => first generation
	S Semi-direct intake				
TL	E Energy-optimized (optimized motor)	Exception: For PL compressors the capacity at rating point is stated.	KT R600a LBP/(MBP) tropical	K = LST characteristics (capillary tube)	.2 => second generation .3 => third generation
	X, Y High Energy-optimized (high optimization level)				
NL					etc.

Examples

PL	E	35	K		
TL	ES	6	KT	K	
NL	X	15	K	K	.2

Application range

- All compressors for R600a have denominations ending with **K** after the number for displacement or capacity. They are designed for low operating temperatures - **LBP (Low Back Pressure)** for use in refrigerators, freezers and similar applications.
- Compressors with endings **K** and **KK** are designed for regions with stable supply voltage.
- Endings **KTK** are designed for less stable supply voltage and tropical conditions. Some of the smaller compressors and the variable speed compressors are also released for medium operating temperatures - **MBP (Medium Back Pressure)**.

Warnings

- R600a is flammable in concentrations of air between approximately 1.5% and 8.5% by volume (LEL lower explosion limit and UEL upper explosion limit).
- An ignition source at a temperature higher than 460°C is needed for a combustion to occur.
- Yellow warning label:



- Isobutane is significantly different from R12 and R134a. This means that compressors for R600a cannot be used with R12 or R134a.
- No high potential test nor start tests must be carried out while the compressor is under vacuum.
- No attempt must be made to start the compressor without a complete starting device.
- Allow the compressor to assume a temperature above 10°C before starting the first time in order to avoid starting problems.
- Anti-freeze agents must not be used in the compressors as such agents are damaging to several of the materials used. In particular, the ethyl or methyl alcohol contents of such anti-freeze agents have a destructive effect on the synthetic motor insulation.

Dimensions

Height [mm]		Connectors location/I.D. [mm]		
A	B	Suction C	Pro-cess D	Dis-charge E
137	135	6.2	6.2	5.0
163	159	6.2	6.2	5.0
163	159	6.2	6.2	5.0
163	159	6.2	6.2	5.0
163	159	6.2	6.2	5.0
163	159	6.2	6.2	5.0
173	169	6.2	6.2	5.0
190	183	6.2	6.2	5.0
190	183	6.2	6.2	5.0
190	183	6.2	6.2	5.0
190	183	6.2	6.2	5.0
197	190	6.2	6.2	5.0
163	159	6.2	6.2	5.0
163	159	6.2	6.2	5.0
163	159	6.2	6.2	5.0
163	159	6.2	6.2	5.0
173	169	6.2	6.2	5.0
173	169	6.2	6.2	5.0
173	169	6.2	6.2	5.0
173	169	6.2	6.2	5.0
173	169	6.2	6.2	5.0
173	169	6.2	6.2	5.0
173	169	6.2	6.2	5.0
173	169	6.2	6.2	5.0
203	197	6.2	6.2	5.0
203	197	6.2	6.2	5.0
203	197	8.2	6.2	6.2
203	197	8.2	6.2	6.2
203	197	8.2	6.2	6.2
203	197	8.2	6.2	6.2
203	197	8.2	6.2	6.2
203	197	8.2	6.2	6.2
173	169	6.2	6.2	5.0
173	169	6.2	6.2	5.0
173	169	6.2	6.2	5.0
173	169	6.2	6.2	5.0
173	169	6.2	6.2	5.0
173	169	6.2	6.2	5.0
197	191	6.2	6.2	5.0
197	191	6.2	6.2	5.0
197	191	6.2	6.2	5.0
203	197	6.2	6.2	5.0

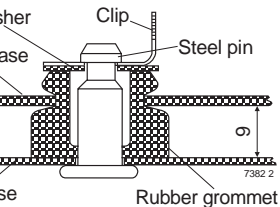

Quantities: 118-1919

Available in two versions, of the baseplate.

LST - RSCR

LST - RSIR

PLE

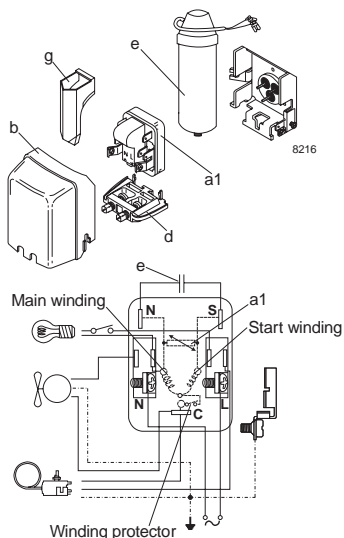

TLES/TLX/TLY - NLE/NLX

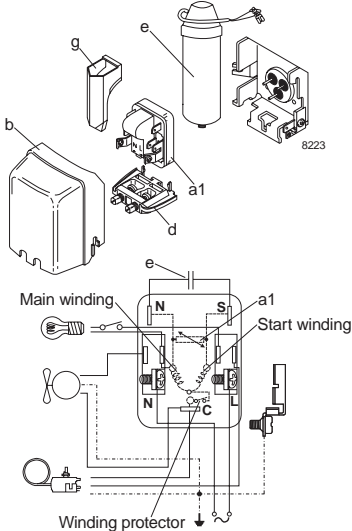

TLES/TLY - NLE

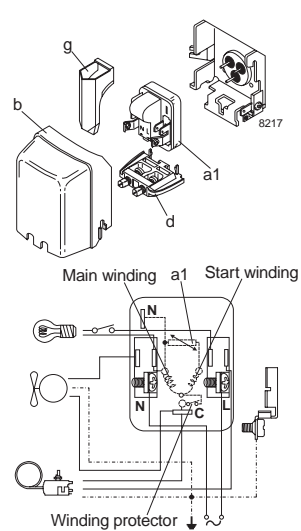

Protection screen for PTC

Run capacitor holder

Run capacitor holder assembly sequence

Note:

To fulfil the requirements of EN 60355-2-34 the protection screen 103N0476 must be applied to the PTC starting device.

A run capacitor holder is available for the „Energy-optimized“ and „High Energy-optimized“ compressor range. This optional part enables to fix the run capacitor for 220V directly and earth-connected on the compressor shell, concentrating all electrical accessories on the compressor. This will save space in the machine compartment.

Code numbers:

- run capacitor holder** 117-0300
- screw M4 x 8 PZD 2** 117-0301

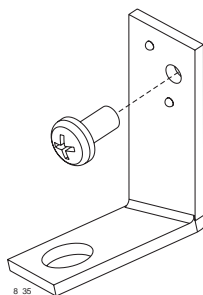
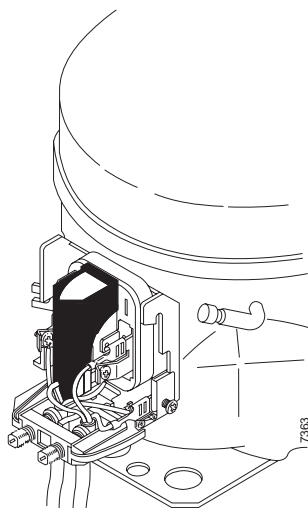
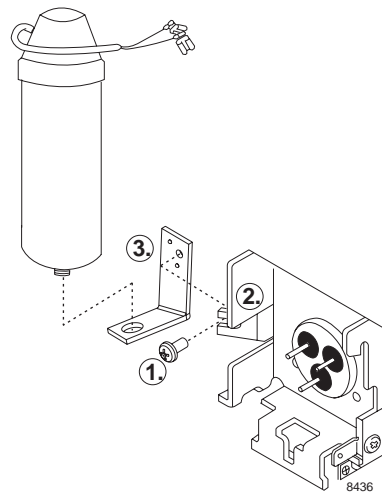

Electronically controlled PTC (ePTC)

Introduction

The asynchronous motor of a single phase AC powered compressor has two windings, a main and an auxiliary winding. The auxiliary winding is powered high at start by means of a starting device, then powered down, often still utilized continuously by means of a run capacitor. The starting device of our standard PTC-starters is a "Positive Temperature Coefficient" resistor, PTC. When heated up during the start phase, the PTC almost cuts off the current to the auxiliary winding, leaving only enough current to keep itself heated to this closing level. The heat loss for this amount to approximately 2.5 W. With the ePTC this loss can be reduced down to approximately 0.4 W by an extra electronic circuit.

The ePTC solution is an easy way to save energy in existing and future freezer and refrigerator designs. It is fully interchangeable with the conventional PTC types 103N0018 and 103N0021 with 4.8 mm spade connectors.

Advantages:

- 2 watt power consumption reduction
- Short recovery time (re-start possible after few seconds if pressure is equalized)
- Can be used to reach a higher cabinet energy class
- Can be used to replace a run capacitor in connection with e.g. a TLES compressor
- Run capacitor acceptance

Functional Description

The main component of the ePTC is the same PTC pill like in other 220-240 V 103N.... Danfoss PTC starters. Thus the start of the compressor motor is performed in the same way. In standard PTC starters the >2 W energy loss to keep the PTC heated during compressor operation are not avoidable. In the ePTC a small electronic circuit cuts off the current through the PTC short time after start and thus reduces the energy loss down to approx 0.4 W. The switch used is a Triac, an electronic AC switch, controlled by a timer circuit.

As the timer circuit has a short reset time and the main PTC cools down during compressor operation already, the full start torque will be available after approx 6 s compressor off time. However, it is still a LST starting device, needing full pressure equalization before start.



ePTC (code number 103N0050)

Legend

- a1:** PTC starting device
- a2:** Starting relay
- a3:** Starting device

- b:** Cover
- b1:** Clamp (part of compressor)
- b2:** Gasket (part of compressor)

- c:** Starting capacitor
- d:** Cord relief
- e:** Run capacitor
- g:** Protection screen for PTC



Applications

Our compressor range will perfectly fit various applications like:

- Refrigerators and freezers
- Laboratory and medical equipment
- Clip-on and condensing units
- Compressed air dryers
- Glass door merchandisers
- Bakery refrigeration equipment
- Low temperature display cabinets
- Vending machines
- Ice making machines
- Slush and frozen beverage makers
- Bottle coolers

Refrigeration Controls programme consists of:

<p>Thermostatic expansion valves</p>	<p>Hermetic filter drier with solid core</p>	<p>Direct or servo operated solenoid valve</p>	<p>Sight glass with moisture indicator</p>