

A COMPLETE AND RELIABLE SYSTEM

TelevisGo is a device for the monitoring, control and remote management of installations.

The product is based on a PC Embedded standard platform to offer greater calculation power, data filing space and, thanks to the Microsoft Embedded operating system, easy system expansion using standard peripherals available on the market.

TelevisGo is an open system, it automatically recognises Eliwell controllers and integrates third-party measuring and control devices equipped with modbus protocol, without the use of additional interfaces.

The open protocol Data Transfer XML allows data exchange via TCP/IP for the centralisation of information. It also allows remote adjustment of installation control parameters, optimising their management with automatic systems.



Data recording and Alarm management

- Recording temperature / pressure / humidity / digital inputs and outputs / functional statuses
- Recording alarm conditions and signaling by email and SMS



Energy reports

- Connection to energy meters with MODBUS protocol
- Dashboards dedicated to the real time and historic display of energy consumption
- Graphic display of energy consumption combined with the functional parameters of the installation



Graphic display

- Display and access to data and parameters of the controllers by means of a freely configurable graphic interface
- HTML interface accessible by most browsers for PC, tablet and smartphone (Internet Explorer, Mozilla, Firefox)
- The graphic interface can be planned off-line with the tools freely available for download from the site www.eliwell.com



Web Connectivity

- All TelevisGo functions are accessible in remote mode with a web browser
- It is possible to access all the historic and real time information and to interact with each controller connected to the system to change its parameters and activate the functions
- The complete management of TelevisGo is included (configuration, updating, restarting of the device)
- TelevisGo can be connected to the Internet with ADSL, 3G or 4G connections, or by configuring the LAN/WAN network to which the device is connected



Activity automation

- Automation of recurrent activities such as switching the lights on and off for energy saving
- Periodic sending by e-mail of detailed reports in PDF format
- Periodic transfer of data to centralised systems for performance analysis



Algorithms and Expandability with IEC 61131

Not available in LE versions

- System extensions with new plug-n-play algorithms installable from the web interface
- Algorithms for management of floating evaporation, faulty pressure probe backup and distribution of the dewpoint for energy saving functions with RTX600 /V and EWCM 9000 EO
- System for the development of new algorithms for distributed management of the installation based on FREE Studio with standard languages IEC 61131

TELEVIS - FLEXIBLE CONNECTIVITY

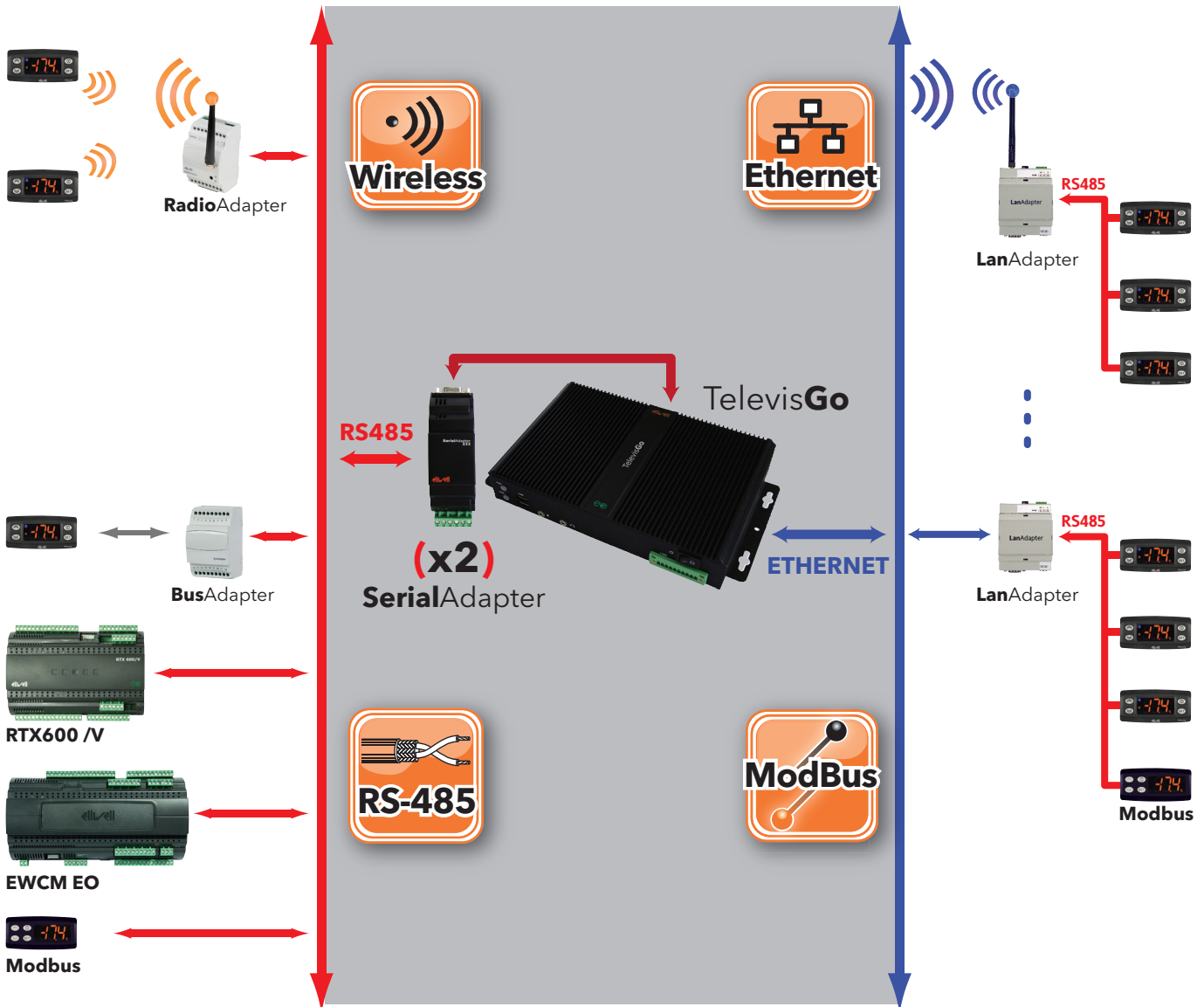

TECHNICAL DATA

FEATURES

Field bus with galvanically isolated adapter	
<ul style="list-style-type: none"> Serial: RS232/RS485 (SerialAdapter) Network: Ethernet/RS485 (LanAdapter) or WiFi/RS485 (LanAdapter Wifi) 	<p style="text-align: right;">Max. 2</p> <p style="text-align: right;">Max. 10</p>
Maximum number of devices managed	10 / 30 / 60 / 224 depending on model
Integrated and applied web server, accessible via web pages	YES
User interface languages pre-loaded onto the device	IT-EN-ES-DE-FR PT-PL-NL-RU-CN
Software upgrades by means of USB pen drive and via WEB	YES
Open XML protocol	YES
Power supply	12V \approx with external 100-240 V \sim \pm 10% power supply unit
Max. power absorbed	10W max
LAN: Ethernet RJ45 port	1
Additional ports	<ul style="list-style-type: none"> 1 VGA 1 PS/2 6 USB



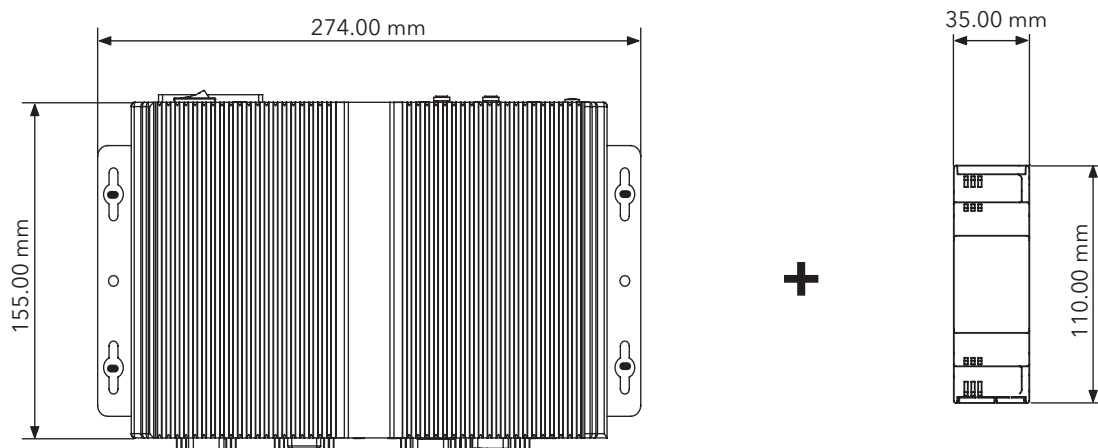



MOUNTING - DIMENSIONS



TelevisGo

SerialAdapter

ACCESSORIES

	SerialAdapter: RS-232 / RS-485 galvanically isolated adapter for TelevisGo.
	LanAdapter / Wifi LanAdapter: galvanically isolated interface for additional RS-485 field bus devices via Ethernet or WiFi network.
	RadioAdapter: wireless mesh field bus for Televis and modbus controllers.
	BusAdapter: RS-485/TTL galvanically isolated adapter for Eliwell controllers not equipped with a serial port.
	Belden AWG20 cable: specific cable for networks RS-485.
	GSM modem: GSM/GPRS modem for the transmission of SMS messages and backup connectivity.

Follow us on  

www.eliwell.com

ELIWELL CONTROLS srl

Via dell' Industria, 15 Z.I. Paludi
32010 Pieve d' Alpago (BL) - ITALY -
T: +39 0437 986 111

Sales:

T: +39 0437 986 100 (Italy)
+39 0437 986 200 (other countries)
E: saleseliwell@schneider-electric.com

Technical Support:

T: +39 0437 986 300
E: Techsuppliwel@schneider-electric.com

