

Data sheet

# Pressure switch

## Type KP



The KP pressure switches can be used as safety switches against too low a suction pressure and/or too high a discharge pressure in refrigeration and air conditioning systems. They can also be used to start/stop compressors and fans for air-cooled condensers.

They are available in both single and dual versions and include a single pole double throw (SPDT) switch.

**Features**

- Ultra-short bounce time thanks to snap-action function (reduces wear to a minimum and increases reliability)
- Available with gold-plated contacts
- SPDT switch design  
Offers open or close switching action on pressure rise or fall
- Fail safe double bellows  
Prevent refrigerant loss and system contamination - standard on KP 7 and KP 17 pressure controls
- Convenient manual trip feature  
To test electrical contact function - no tools needed
- Pressure wire connectors  
For easy electrical wiring
- No spade or lug terminals required
- Integral ½ NPSM swivel cable connector  
Allows direct attachment of ½ in. male pipe thread connector
- Lockplate  
Prevents tampering with range and differential settings
- Universal mounting hole patterns

**Approvals**

UL listed for USA and Canada, file E31024

Technical data

Ambient temperature	-40 – 149 °F (175 °F for maximum 2 hours)
Maximum working pressure	LP: PS/MWP = 245 psig
	HP: PS/MWP = 465 psig
Maximum test pressure	LP: Pe = 285 psig
	HP: Pe = 510 psig
Switch	Single pole changeover switch (SPDT)
Contact load	120 V a.c.: 16 FLA, 96 LRA
	240 V a.c.: 8 FLA, 48 LRA
	240 V d.c.: 12 W pilot duty
Terminal D, dual controls	240 V, 50 VA

*Cable entry*

Integral 1/2 in. female NPSM swivel cable connector allows direct attachment of 1/2 in. male pipe thread connector.

*Enclosure*

~NEMA 1

This grade of enclosure is obtained when the units **without** top cover are mounted on a flat surface or bracket. The bracket must be fixed to the unit so that all unused holes are covered.

~ NEMA 2

This grade of enclosure is obtained when the units **with** top cover are mounted on a flat surface or bracket. The bracket must be fixed to the unit so that all unused holes are covered.

*Materials in contact with the medium*

Control type	Material
KP 1, KP 2, KP 5, KP 7, KP 15, KP 17, KP 25	Tin bronze, no. CW452K, EN 1652 Nickel plated free cutting steel, no. 1.0737 / 1.0718 to EN 10277
KP with cap. tube	Copper SF-Cu, no. 2.0090 to DIN 1787

Technical data

Electrical wiring

Low or high pressure	
Dual (low and high) pressure, LP signal	Dual (low and high) pressure, LP and HP signal
Low pressure, LP: KP 1 and KP 2	High pressure, HP: KP 5, KP 7W and KP 7B
Dual (low and high) pressure: KP 15, KP 17W, KP 17B and KP 25	Dual (low and high) pressure: KP 15, KP 17W, KP 17B and KP 25



Load



Signal option



Bellows movement on pressure rise



Bellows movement on pressure drop

Metric conversions  
 1 psi = 0.07 bar  
 $\frac{5}{9} (t_1 \text{ } ^\circ\text{F} - 32) = t_2 \text{ } ^\circ\text{C}$

Ordering

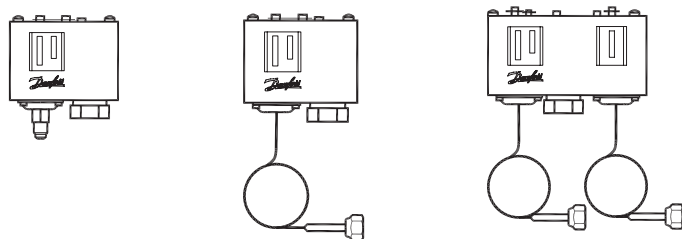

For HCFC and non-flammable HFC refrigerants

Pressure	Type	Low pressure (LP)		High pressure (HP)		Reset		Contact functio	Code no.	
		Regulating range [inHg] [psig]	Differential Δp [psi]	Regulating range [psig]	Differential Δp [psi]	Low pressure [LP]	High pressure [HP]		connection	
									¼ in. flare	Cap. tube w. ¼ in. flare nut 36 in.
Low	KP 1	6 in. – 108	10 – 58	—	—	Auto	—	SPDT	060-200166	—
Low	KP 1	6 in. – 108	10 – 58	—	—	Auto	—	SPDT	—	060-205166
Low	KP 1	27 in. – 100	10	—	—	Man. (Min.)	—	SPDT	—	060-205266 <sup>1)</sup>
Low	KP 2	6 in. – 50	6 – 32	—	—	Auto	—	SPDT	060-2013 66	—
Low	KP 2	6 in. – 50	6 – 32	—	—	Auto	—	SPDT	—	060-206366
High	KP 5	—	—	115 – 465	25 – 85	—	Auto	SPDT	060-201466	—
High	KP 5	—	—	115 – 465	25 – 85	—	Auto	SPDT	—	060-206466
High	KP 7W <sup>2)</sup>	—	—	115 – 465	58 – 140	—	Auto	SPDT	060-200366	—
High	KP 7W <sup>2)</sup>	—	—	115 – 465	58 – 140	—	Auto	SPDT	—	060-205366
High	KP7B <sup>2)</sup>	—	—	115 – 465	58	—	Man. (Max.)	SPDT	060-200466	—
High	KP7B <sup>2)</sup>	—	—	115 – 465	58	—	Man. (Max.)	SPDT	—	060-205466
Dual	KP 15	6 in. – 108	10 – 58	115 – 465	58	Auto	Auto	SPDT/w. L P signal	060-200866	—
Dual	KP 15	6 in. – 108	10 – 58	115 – 465	58	Auto	Auto	SPDT/w. L P signal	—	060-205866
Dual	KP 15	6 in. – 108	10 – 58	115 – 465	58	Auto	Man. (Max.)	SPDT/w. L P signal	—	060-205966
Dual	KP 15	6 in. – 108	10 – 58	115 – 465	58	Man. (Min.)	Man. (Max.)	SPDT/w. L P signal	—	060-206066
Dual	KP 15	6 in. – 108	10 – 58	115 – 465	58	Auto	Auto	SPDT/w. LP + HP signal	—	060-203166
Dual	KP 15	6 in. – 108	10 – 58	115 – 465	58	Auto	Man. (Max.)	SPDT/w. LP + HP signal	060-202666	—
Dual	KP 17W <sup>2)</sup>	6 in. – 108	10 – 58	115 – 465	58	Auto	Auto	SPDT/w. LP + HP signal	—	060-202966
Dual	KP 17W <sup>2)</sup>	6 in. – 108	10 – 58	115 – 465	58	Auto	Auto	SPDT/w LP signal	—	060-205566

<sup>1)</sup> With dial knob

<sup>2)</sup> With fail safe double bellows

Metric conversions

1 psi = 0.07 bar

$\frac{5}{9} (t_1 \text{ } ^\circ\text{F} - 32) = t_2 \text{ } ^\circ\text{C}$

Design

Pressure switch, type KP

KP 1, KP 2, KP 5

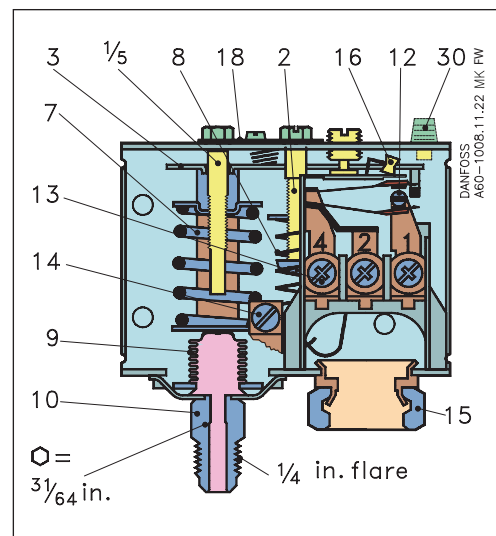
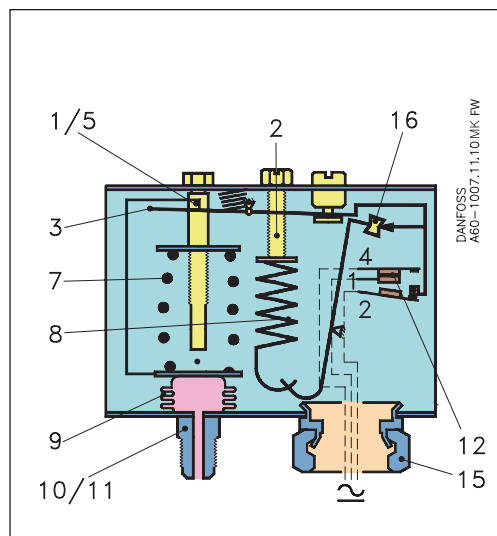

KP 15, KP 25 flare

KP 1, KP 2, KP 5, KP 15, KP 25, KP 7W, KP 7B, KP 17W, capillary tube

1. Low pressure setting spindle, (LP)
2. Differential setting spindle
3. Main arm
5. High pressure setting spindle, (HP)
7. Main spring
8. Differential spring
9. Bellows
10. LP connection
11. HP connection
12. Switch
13. Terminals
14. Earth terminal
15. Cable entry
16. Tumbler
18. Locking plate
19. Arm
30. Reset button

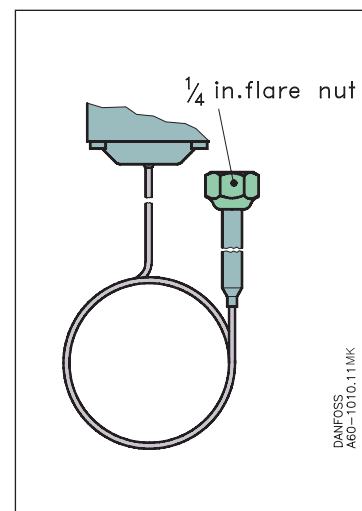
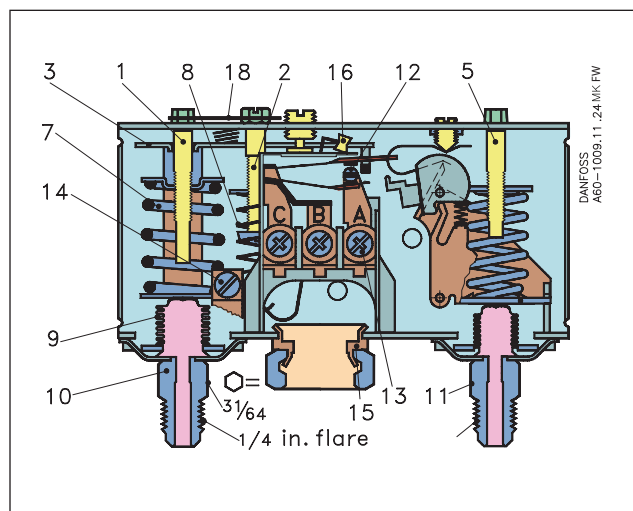

The switch in the KP has a snap-action function where the bellows move only when the cut-in or cut-out value is reached.

The bellows are connected to the low or high pressure side of the system through connection (10) or (11).

The design of the KP gives the following advantages:

- high contact load
- ultra-short bounce time
- high resistance to pulsation
- vibration resistance up to 4 g in the range 0 - 1000 Hz
- long mechanical and electrical life

**Design**  
(continued)

KP 7W (KP 7B), flare

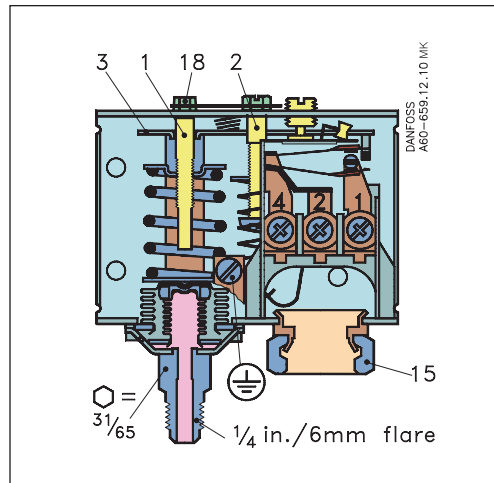

KP 7W (KP 7B), capillary tube

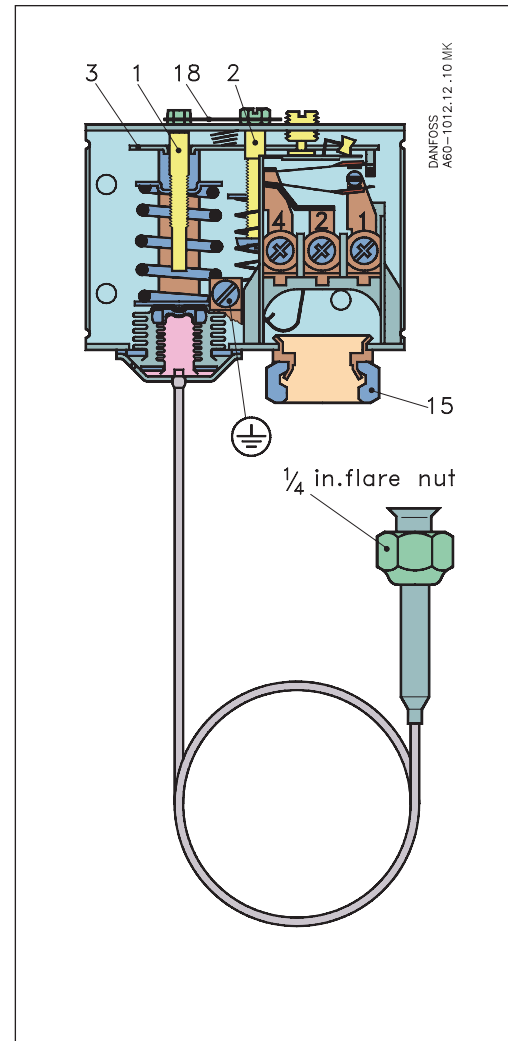

KP 17W (KP 17B), flare

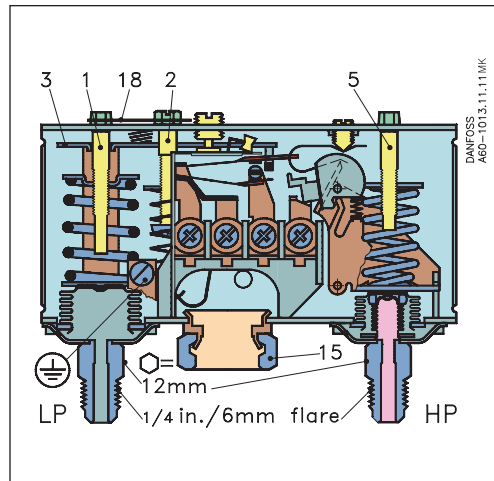

- 1. Pressure setting spindle, (LP)
- 2. Differential setting spindle
- 3. Main arm
- 5. Pressure setting spindle, (HP)
- 15. Cable entry
- 18. Locking plate

The KP with designations W or B have been tested and approved by TÜV (Germany) in accordance with EN 12263.

Versions with designation W will cut in automatically when the pressure has fallen to the setpoint minus the differential.

Versions with designation B can be cut in manually using the external reset button when:

KP 1 – the pressure has increased to 10 psi above the setpoint.

KP 7 – the pressure has fallen 58 psi below the setpoint.

KP 7 and KP 17 are equipped with fail-safe double bellows; a regulation bellows and an outer bellows. The double bellows system protects against loss of system charge in the event of a bellows rupture.

A rupture in the outer bellows will cause the control to trip approximately 43 psi lower than the actual control setting. This feature provides a warning without a loss of charge.

All KP pressure switches, including those which are PED-approved, operate independently of changes in the ambient temperature around the control housing. Therefore the set cut-out pressure and differential are kept constant provided the permissible ambient temperatures are not exceeded.

**Terminology**

*Reset*

1. Manual reset:  
Units with manual reset can only be reset during operation by activation of the reset button.
2. Automatic reset:  
After operational stop, these units reset automatically.

*Maximum working pressure*

The Maximum working pressure is determined by the pressure that can be safely allowed in the refrigerating system or any of the units within it. The maximum working pressure is designated MWP.

*Test pressure*

The test pressure is the pressure used in strength tests and/or leakage tests on refrigerating systems or individual parts in systems. The test pressure is designated Pe.

*“Snap function”*

A certain contact force is maintained until irrevocable “snap” is initiated. The time during which the contact force approaches zero is thus limited to a very few milliseconds. Therefore contact bounce cannot occur as a result of, for example, slight vibrations, before the cut-out point. Contact systems with “Snap function” will change over even when micro-welds are created between the contacts during cut-in. A very high force is created during cut-out to separate the contacts. This force immediately shears off all the welds. Thus the cut-out point of the unit remains very accurate and completely independent of the magnitude of the current load.

**Setting**

*Pressure switches with automatic reset – LP:*

Set the LP start pressure on the “CUT-IN” scale (range scale). One rotation of the low pressure spindle ~10 psi. Set the LP differential on the “DIFF” scale. One rotation of the differential spindle ~ 3 psi. The LP cut-out pressure is the LP cut-in pressure minus the differential.

**Note:**

The LP cut-out pressure must be above absolute vacuum  $p_e = 30$  in. Hg. If compressor will not stop at low cut-out pressure, check whether the differential value is set at too high a value!

*Pressure switches with automatic reset – HP:*

Set the HP cut-out pressure on the “CUT-OUT” scale. One rotation of the HP spindle ~ 33 psi. Set the HP differential on the “DIFF” scale. One rotation of the differential spindle ~ 4 psi. The HP cut-in pressure is the HP cut-out pressure minus the differential. Pressure switches with manual reset. Set the cut-out pressure on “CUT-OUT” scale (range scale). Low pressure controls can be manually reset when the pressure is equal to the cut-out pressure plus the differential.

High pressure switches can be manually reset when the pressure is equal to the cut-out pressure minus the differential.

Cut-in and cut-out pressures for both the LP and HP sides of the system should always be checked with an accurate pressure gauge.

Metric conversions  
1 psi = 0.07 bar

Dimensions [in.]  
and weight [lb]

Flare connection

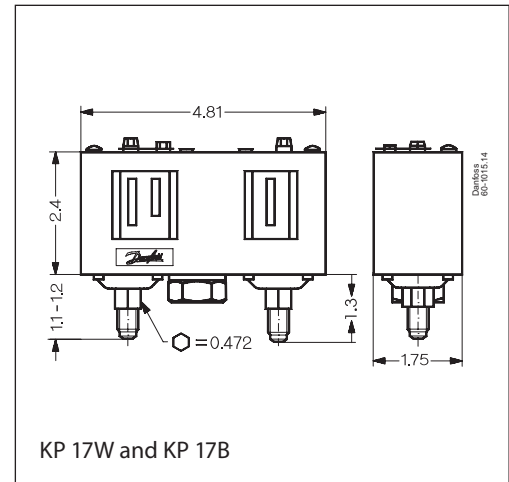
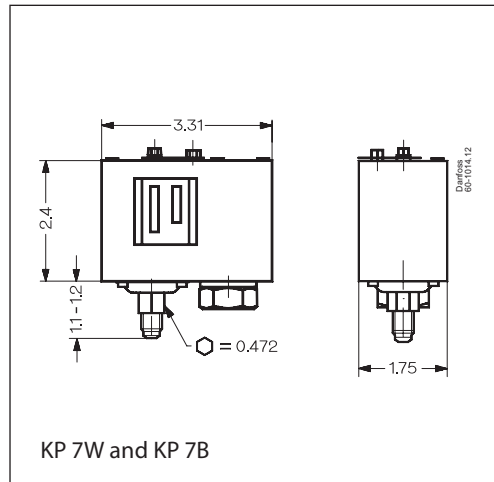
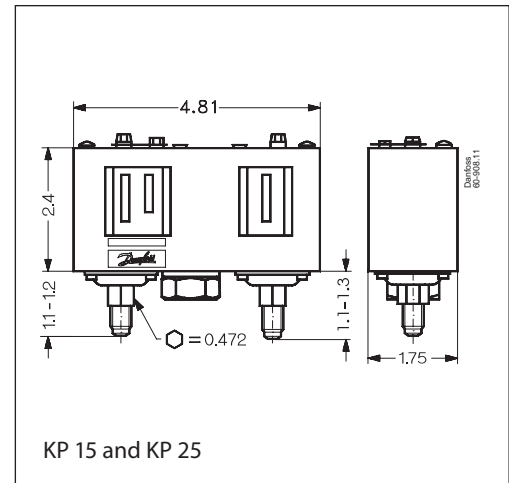
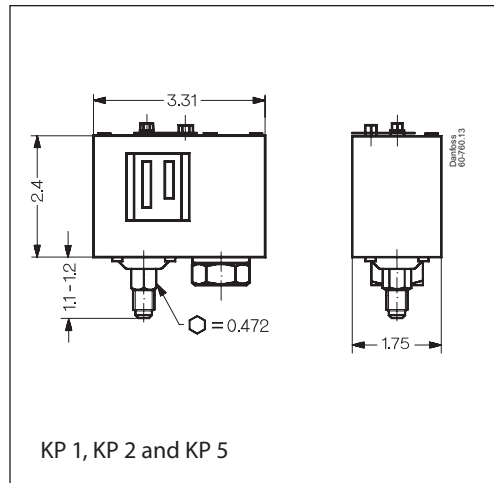

Capillary tube connection

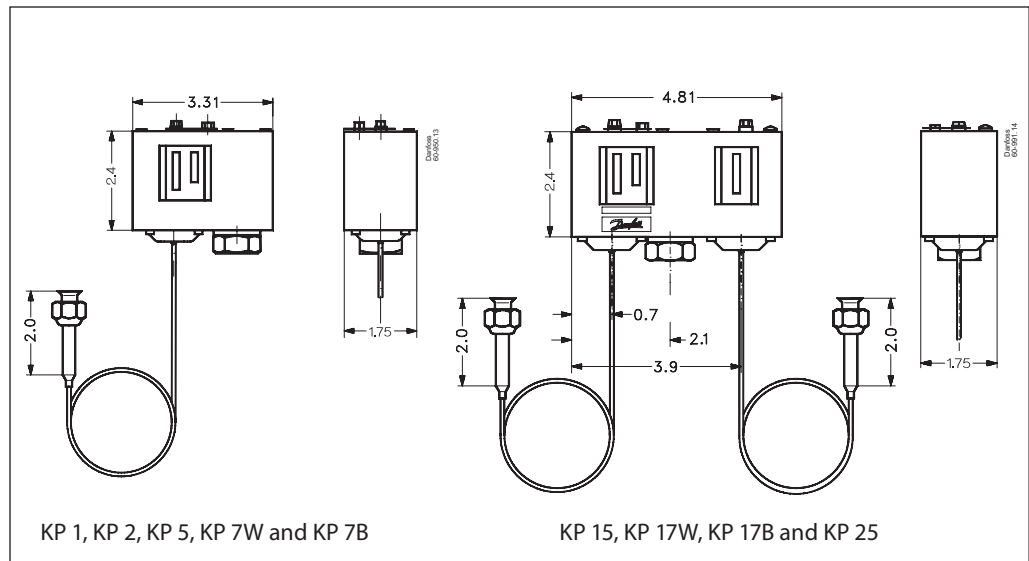

Net weight:  
KP 1, KP 2, KP 5 and KP 7:  
approx. 0.7 lbs.  
KP 15, KP 17 and KP 25:  
approx. 1.1lbs.

Metric conversions  
1 in. = 25.5 mm  
1 lb = 0.454 kg



Dimensions [in.]

KP single switches, rear side

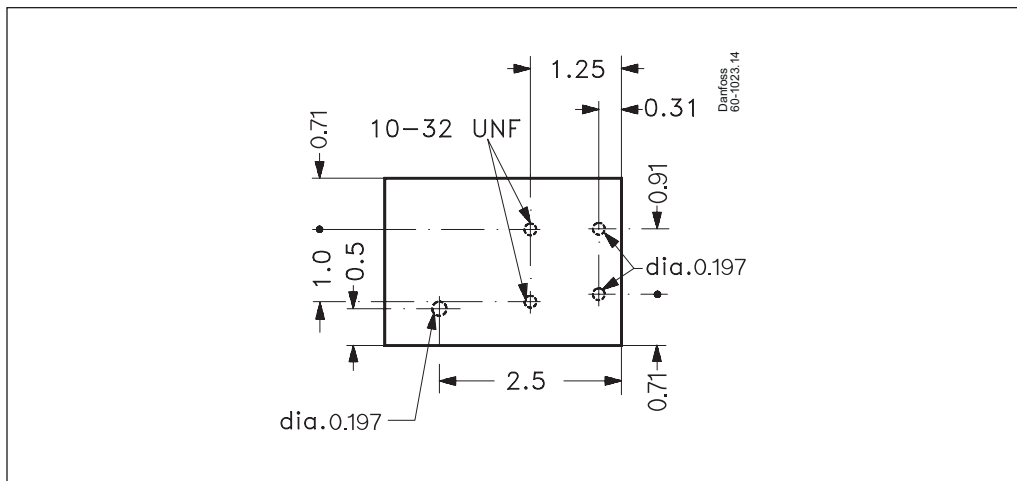

KP dual switches, rear side

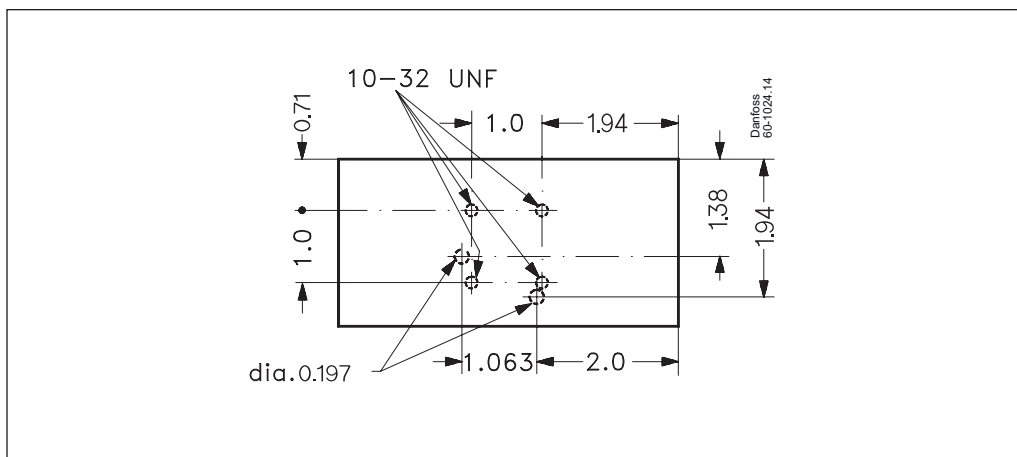

Wall bracket

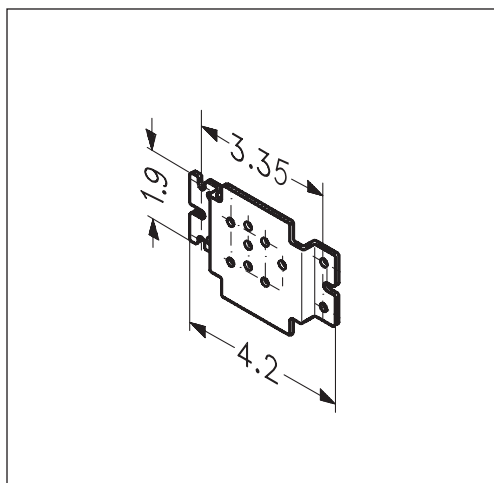

Angle bracket

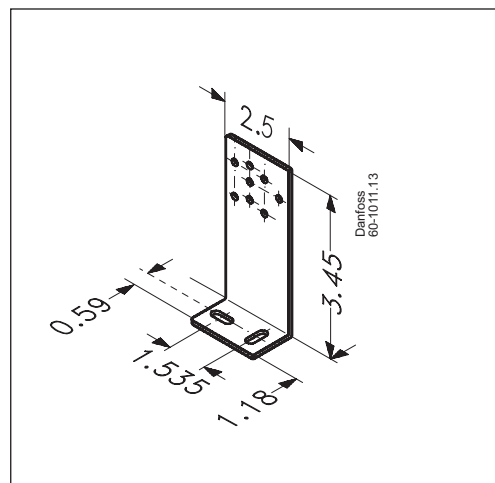

Danfoss can accept no responsibility for possible errors in catalogues, brochures and other printed material. Danfoss reserves the right to alter its products without notice. This also applies to products already on order provided that such alterations can be made without substantial changes being necessary in specifications already agreed. All trademarks in this material are property of the respective companies. Danfoss and the Danfoss logotype are trademarks of Danfoss A/S. All rights reserved.